

English Book Volume - I

Senior Nursery



This book belongs to

Name :.....

Class :..... Sec :.....

Senior Nursery – English Book Volume I

You are free to copy and redistribute the material in any format or medium. You must give appropriate credit and you may not use the material for commercial purposes without the permission of the author. If you remix, transform, or build upon the material, you may not distribute the modified material.

You can write to 'Vedritam Group' (Formerly D.A.V Group, Chennai) 212–213, Avvai Shanmugam Salai, Gopalapuram, Chennai–600086 or email to publications@davchennai.org to seek permission to print all or only certain chapters of the book.

The publisher of this book is solely responsible and liable for its content including but not limited to the views, representations, descriptions, statements, information, opinions and references.

Preface

Early childhood education is not merely about learning letters and numbers—it is about nurturing curious minds, kind hearts, and confident learners. The LKG and UKG Series have been thoughtfully designed to provide young children with a joyful, meaningful, and value-based learning experience rooted in Indian culture and global learning practices.

This English series for example, follows a holistic, phonics-based, and child-centric approach that strengthens the four essential language skills—Listening, Speaking, Reading, and Writing. Through engaging stories, interactive activities, sound families, blends, and simple grammar exercises, children are guided step by step to build strong foundational English skills in a natural and enjoyable way. Recognising that children learn best when learning is connected to life, culture, and emotions, this series integrates Socio-Emotional and Cultural Learning (SECL). Beyond developing academic competence, the books encourage values such as respect, sharing, cleanliness, friendship, perseverance, and service. Stories and activities are carefully woven with Indian Knowledge Systems (IKS), helping children appreciate their heritage while developing a sense of belonging and responsibility.

At the heart of this series lies our proprietary S.A.T.V.I.C. Design Framework:

- **S** – Skill Building through Stories and Activities
- **A** – Activity Before Concept for experiential learning
- **T** – Think Before and After to strengthen understanding
- **V** – Value Integration for character building
- **I** – Indic Knowledge for cultural grounding
- **C** – Co-creation of Knowledge through participation

This framework ensures that learning moves beyond rote memorisation to meaningful exploration, reflection, and creativity.

Each lesson is designed to encourage observation, expression, imagination, and collaboration. The series aims to prepare children not only for academic success but also for life—by nurturing empathy, resilience, cultural awareness, and independent thinking. Teachers and parents are partners in this journey, supporting children as they discover language, values, and their own unique potential. We hope that these books inspire young learners to love reading, enjoy learning, respect their roots, and grow into responsible, compassionate, and confident individuals.

With warm wishes for a joyful learning journey,

Chennai | May 2026

Secretary
Vedritam Group
(Formerly D.A.V Group, Chennai)

UKG Discover Pedagogy

Reading Program (with IKS Integration) - A holistic, phonics-based, values-rooted approach for young learners.

UKG English Learning Approach and Outcomes (Volumes 1 & 2)

The curriculum focuses on developing foundational English skills across **Listening (L)**, **Speaking (S)**, **Reading (R)**, and **Writing (W)**, incorporating phonics through blends and common sound families, alongside storytelling and moral values.

Core Learning Approach

Story Time (Listening & Speaking): Engaging narratives are used to introduce new concepts, language usage, and moral values like getting blessings, sharing, cleanliness (Shoucham), selfless service (Seva), friendliness (Maitri), and grit (Titiksha).

Phonics Focus: Introduction and practice of L-Blends (bl, cl, pl, gl, fl) and R-Blends (br, cr, fr, tr, dr, gr).

Sound Families: Extensive practice with CVC (Consonant-Vowel-Consonant) words grouped by vowel sound families (e.g., -ad, -ag, -an, -ab, -at, -en, -et, -ed, -eg, -in, -it, -ip, -ig, -ib, -im, -ix, -ot, -op, -ob, -og, -od, -ub, -um, -ud, -un).

Digraphs: Introduction and exercises focusing on digraph sounds like sh, ch, th, and wh.

Key Learning Outcomes

I. Phonics and Word Recognition

The student will be able to:

- Identify and pronounce words containing L-Blends and R-Blends, and the blends st, sl, sp, sn.
- Generate words from common sound families (e.g., bat, cat, mat for -at family).
- Identify and use words with digraphs sh, ch, th, wh, ck.
- Fill in missing letters (vowels or blends) to complete words based on pictures.
- Recognize and match rhyming words.

II. Grammar and Vocabulary

The student will be able to:

- Form the plural of simple nouns by adding 's'.
- Use simple prepositions like in, on, and under correctly in context.
- Use the demonstrative pronouns This and That.
- Expand vocabulary by learning new words associated with different blends and sounds (e.g., black, clip, plane, globe, flag, drum, snake, spider, shark, chair, three, wheel, clock).
- Complete sentences using newly learned vocabulary and action words.

III. Reading and Comprehension

The student will be able to:

- Read simple sentences containing short vowel sound words and sight words.
- Comprehend and respond to simple story-based questions.
- Follow written instructions for colouring, circling, matching, and writing.

Acknowledgements

We sincerely acknowledge and appreciate the invaluable contribution of our nursery teachers in developing this textbook. Their dedication, creativity, and deep understanding of young learners have enriched the content, making it engaging and meaningful, and laying a strong and nurturing foundation for their lifelong educational journey.

This content is developed from the original works of Vedritam Group (Formerly D.A.V Group, Chennai) with a significant contribution from Mr. Santhosh Subramanian, Discover Learning.

Wrapper Design

Ms. Hamsavani Raman and Team

Technical Support

Smt. R. Dharshini Ragamathy, B.Sc., M.A

TABLE OF CONTENTS

1	Recap of Alphabet	7
2	'a' family words	18
3	'e' family words	27
4	'i' family words	34
5	'o' family words	44
6	'u' family words	53
7	Digraph - 'sh'	69
8	Digraph - 'ch'	73
9	Digraph - 'th'	78
10	Digraph - 'wh'	84
11	Digraph - 'ck'	88

Recap

Circle the pictures for the given letter.

a

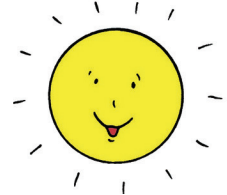
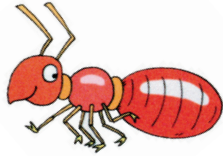

b

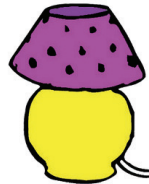
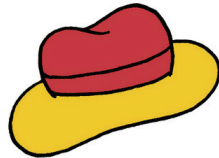

c

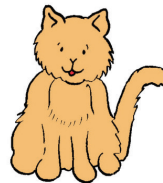
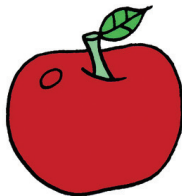

d

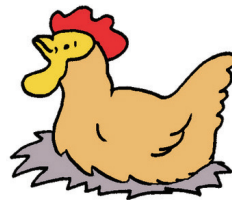
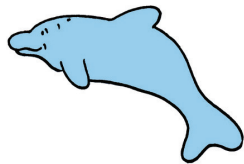

e

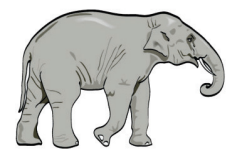
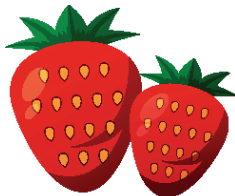

Recap

Circle the pictures for the given letter.

f

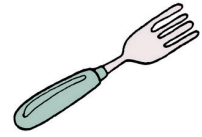
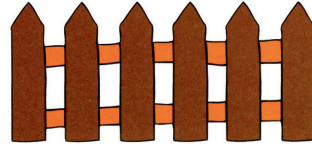

g



h



i



j



k

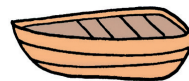
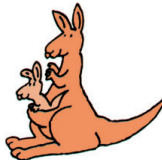

l



Recap

Circle the pictures for the given letter.

m



n

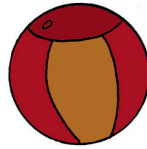

o

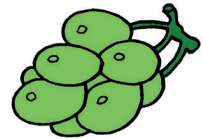
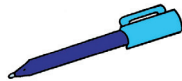

p

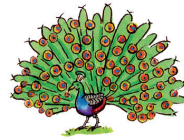

q



r

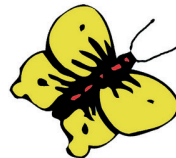
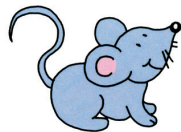

s

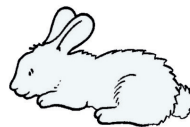

Recap

Circle the pictures for the given letter.

t

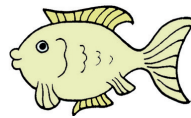
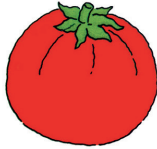

u

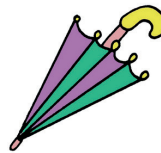

v

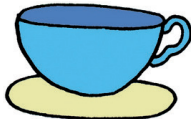

w

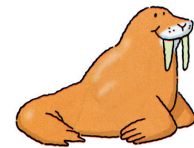

x

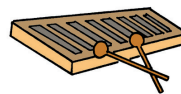

y

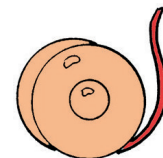

z



Recap

Write the first letter of the pictures.

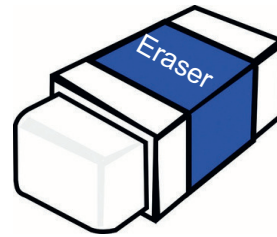
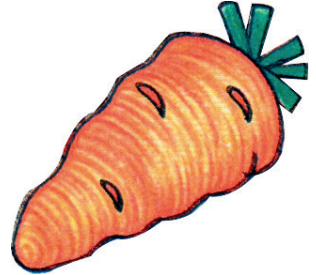
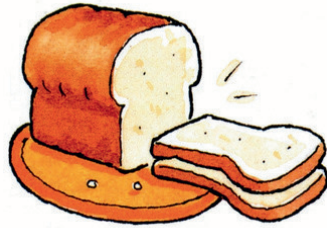
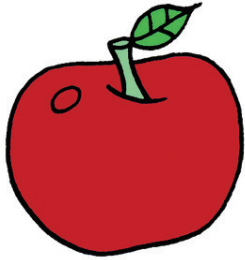

Recap

Write the first letter of the pictures.

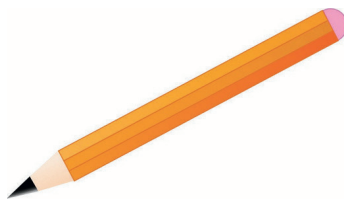
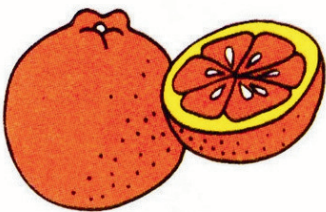
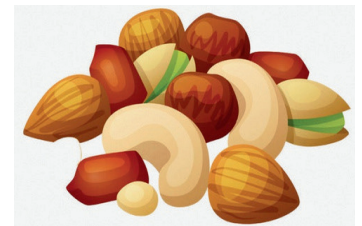
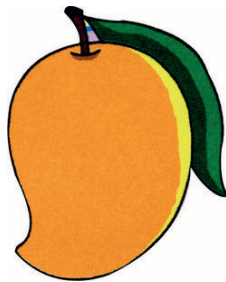
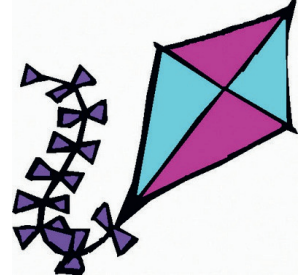

Recap

Write the first letter of the pictures.

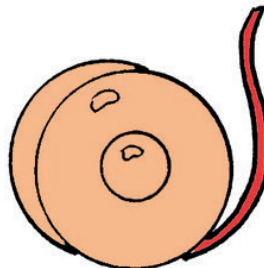

Recap

Join the dots from a-z

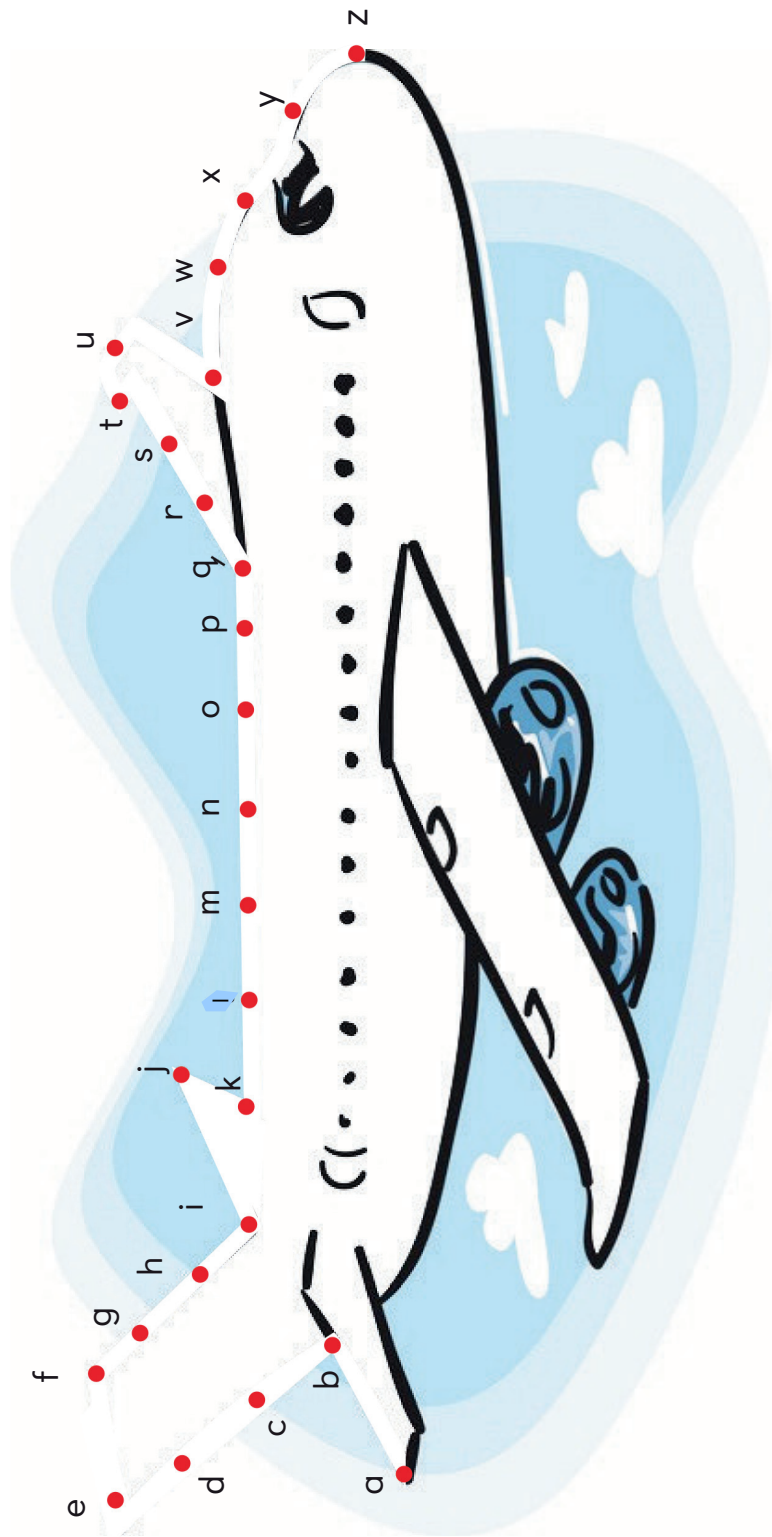

Recap

Join the dots from A - Z and colour.

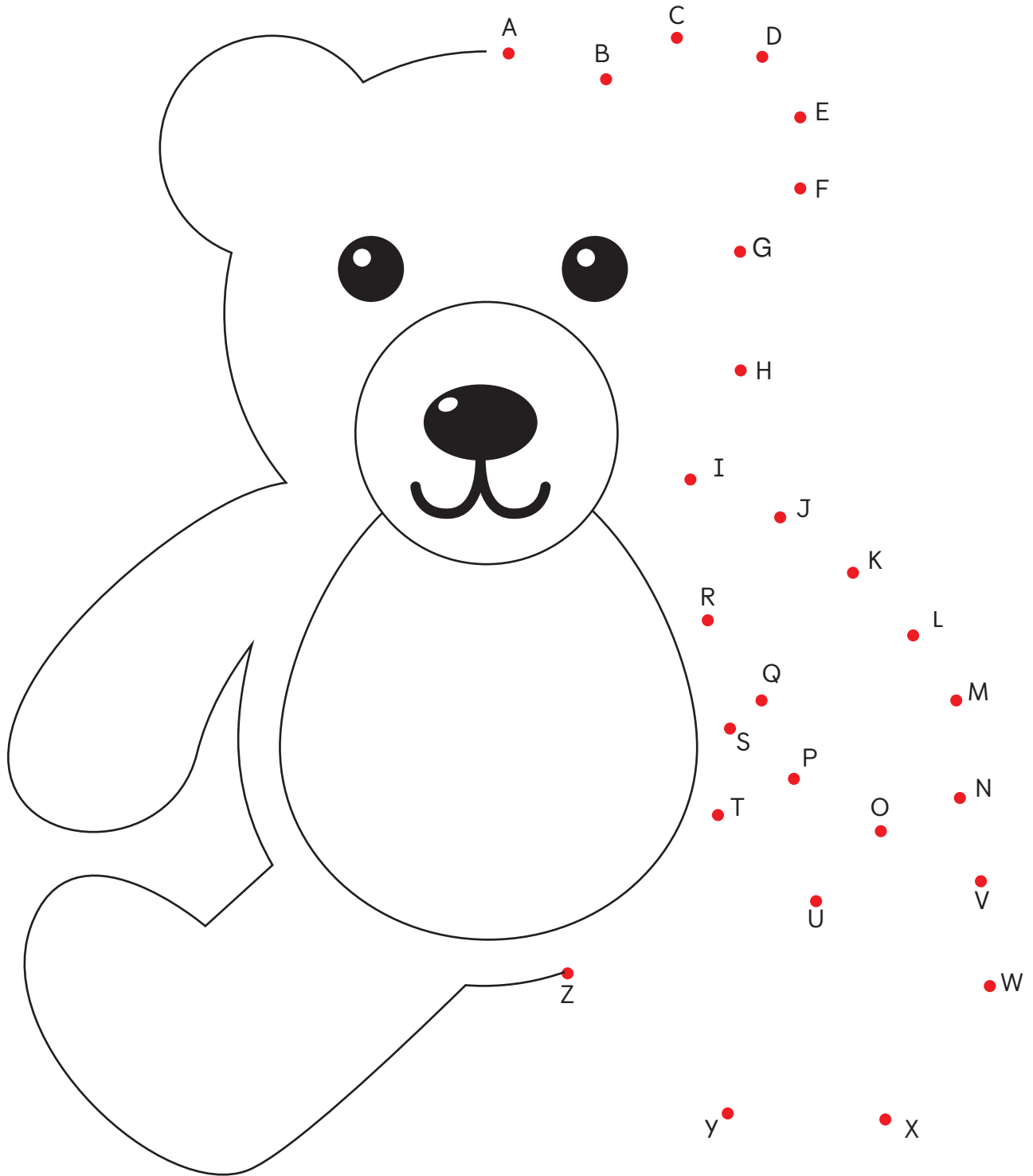

Recap

Draw pictures for the given letters.

a

b

c

d

e

f

g

h

i

j

k

l

m

n

Recap

Draw pictures for the given letters.

o

p

q

r

s

t

u

v

w

x

y

z

Family words - 'a'

_ab

cab

lab

nab

tab

_ad

bad

dad

had

lad

mad

pad

sad

_ag

bag

lag

rag

sag

tag

wag

_an

can

fan

man

pan

ran

tan

van

and

_am

jam

yam

Family words - 'a'

_ap

cap

gap

lap

map

nap

rap

tap

_ar

bar

car

far

jar

tar

war

_as

has

_at

bat

cat

fat

hat

mat

pat

rat

sat

_ay

bay

day

hay

lay

may

pay

say

way

It's story time!

Do you spend more time on phone or with your friends?

Aryan's Grand Day



Little Aryan had his mom's phone to play a game.



He saw his friend, Raghav, wave from the park.



Aryan thought, "Should I play on the phone or go out and play?"

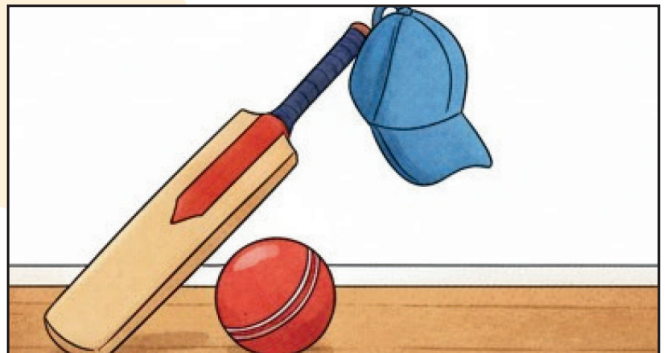

He looked at his shiny new bat and the bright red ball.



He ran to the park, feeling very glad.



Aryan felt happy, knowing it was a grand day!

Make new words.

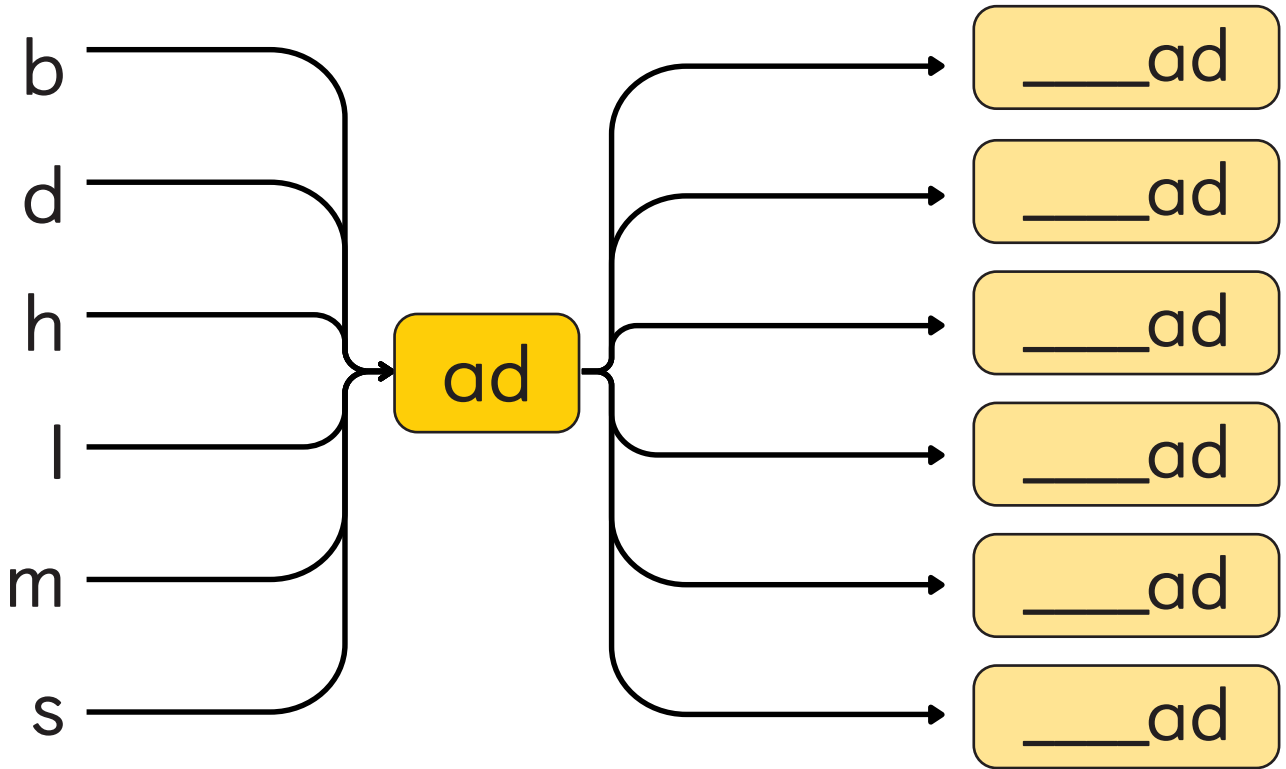
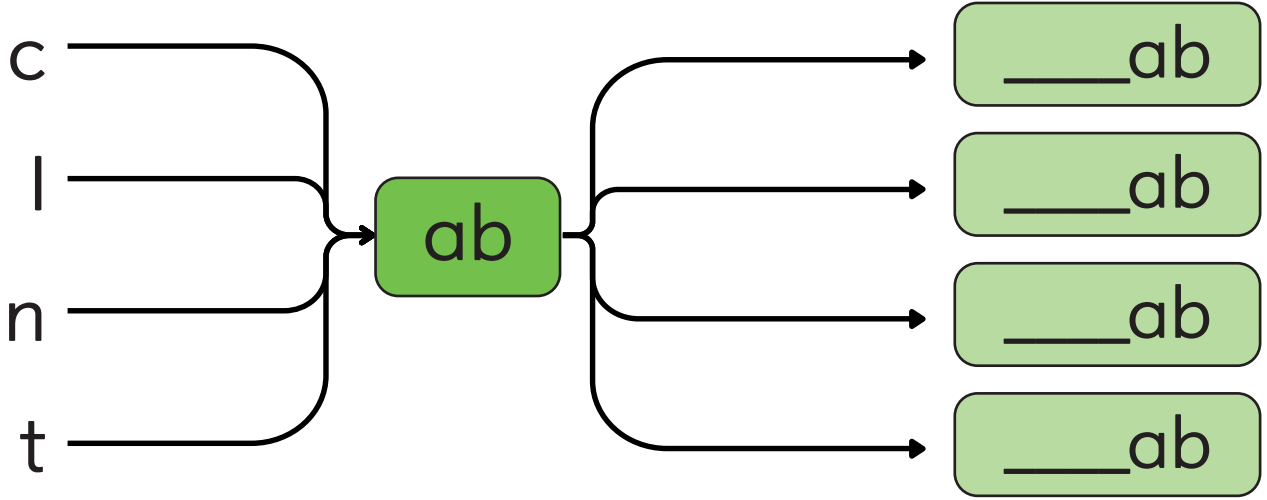

Make new words.

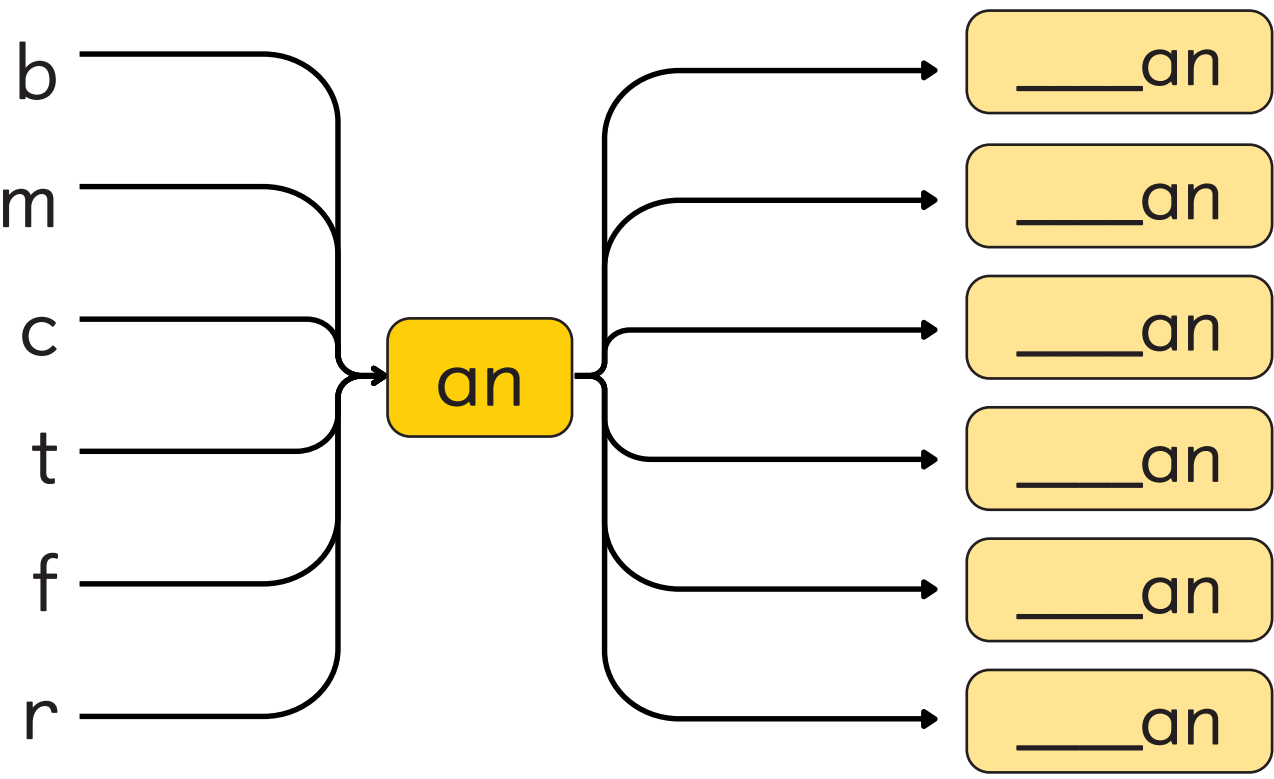
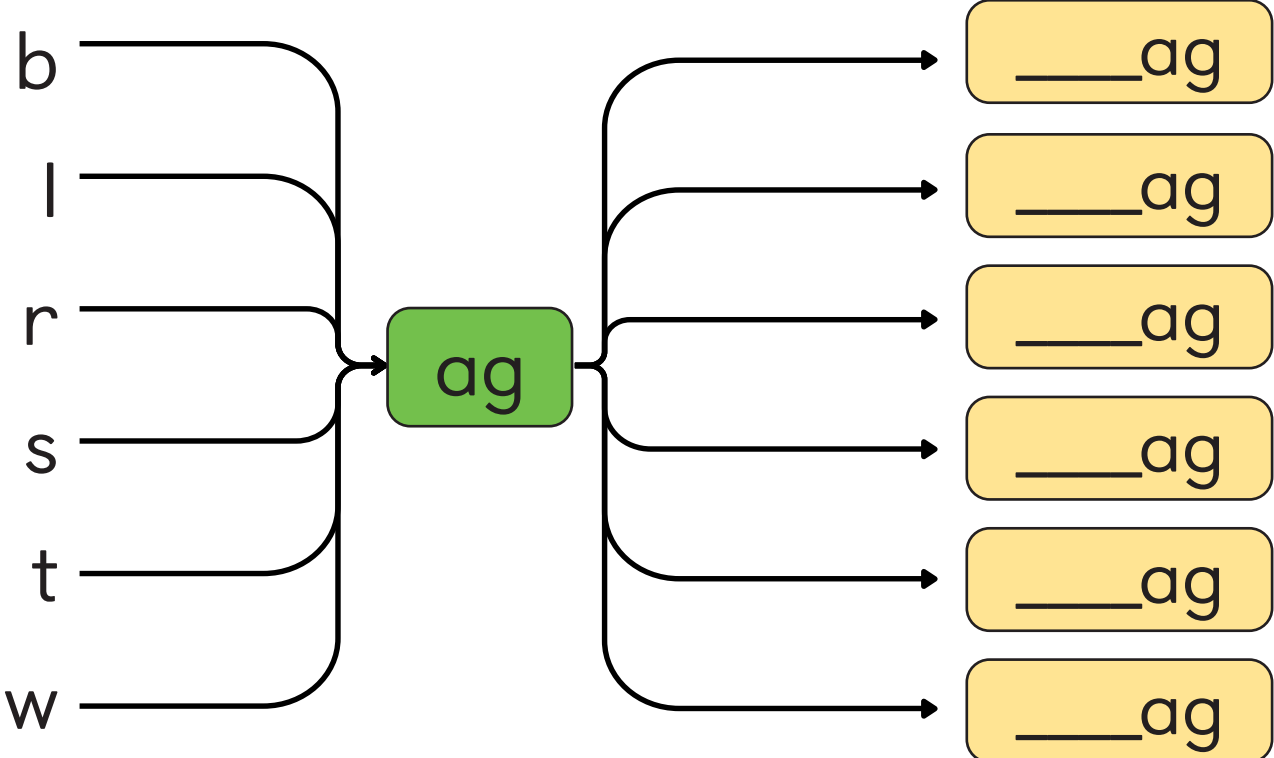

Spot the 'at' words, write and colour them.

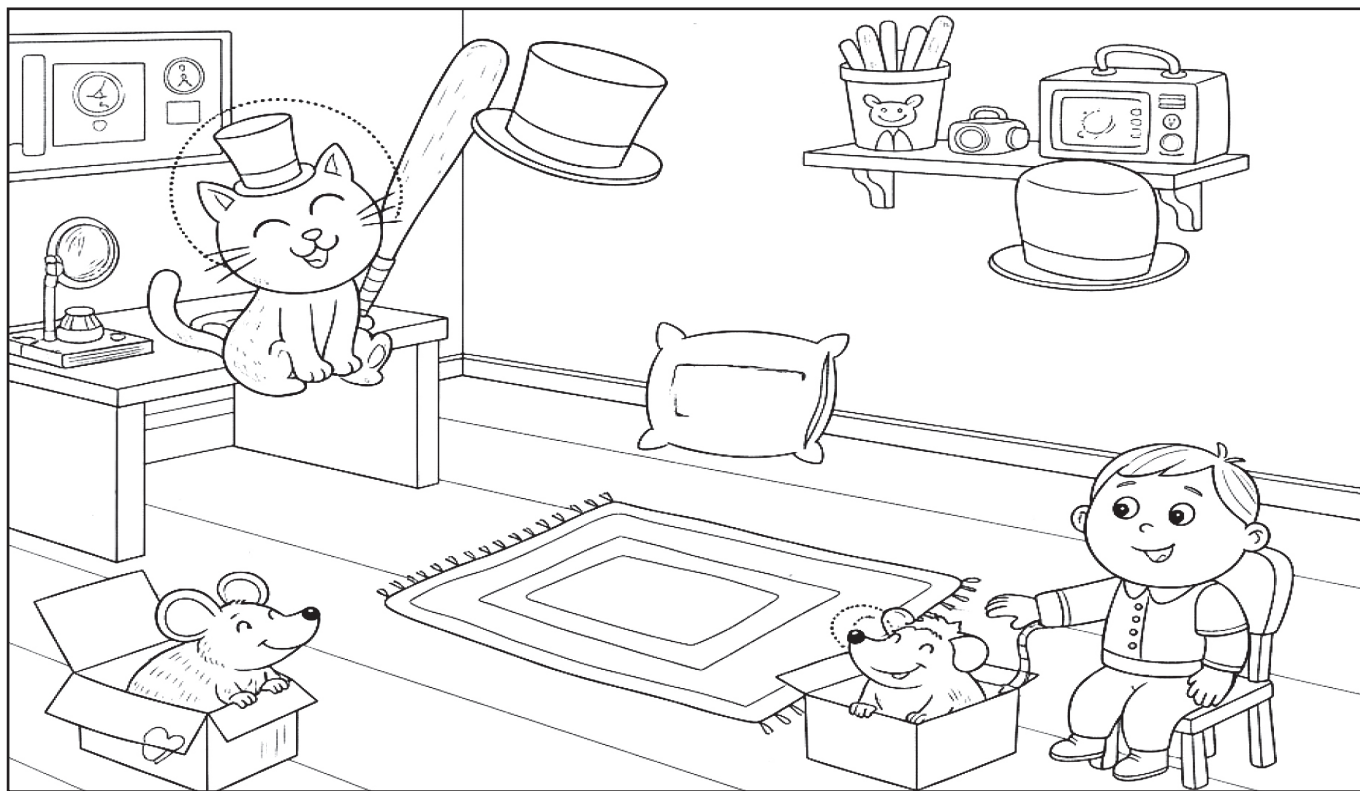

b	}	}	at	}	_____ at
m					_____ at
r					_____ at
s					_____ at
h					_____ at
c					_____ at

Family words



Listen and circle.

can fan
man ran

pan tan
van and

am jam
yam dam

cap gap
lap map

nap tap
rap zap

Family words



Colour the flowers that have letter 'a' in them.

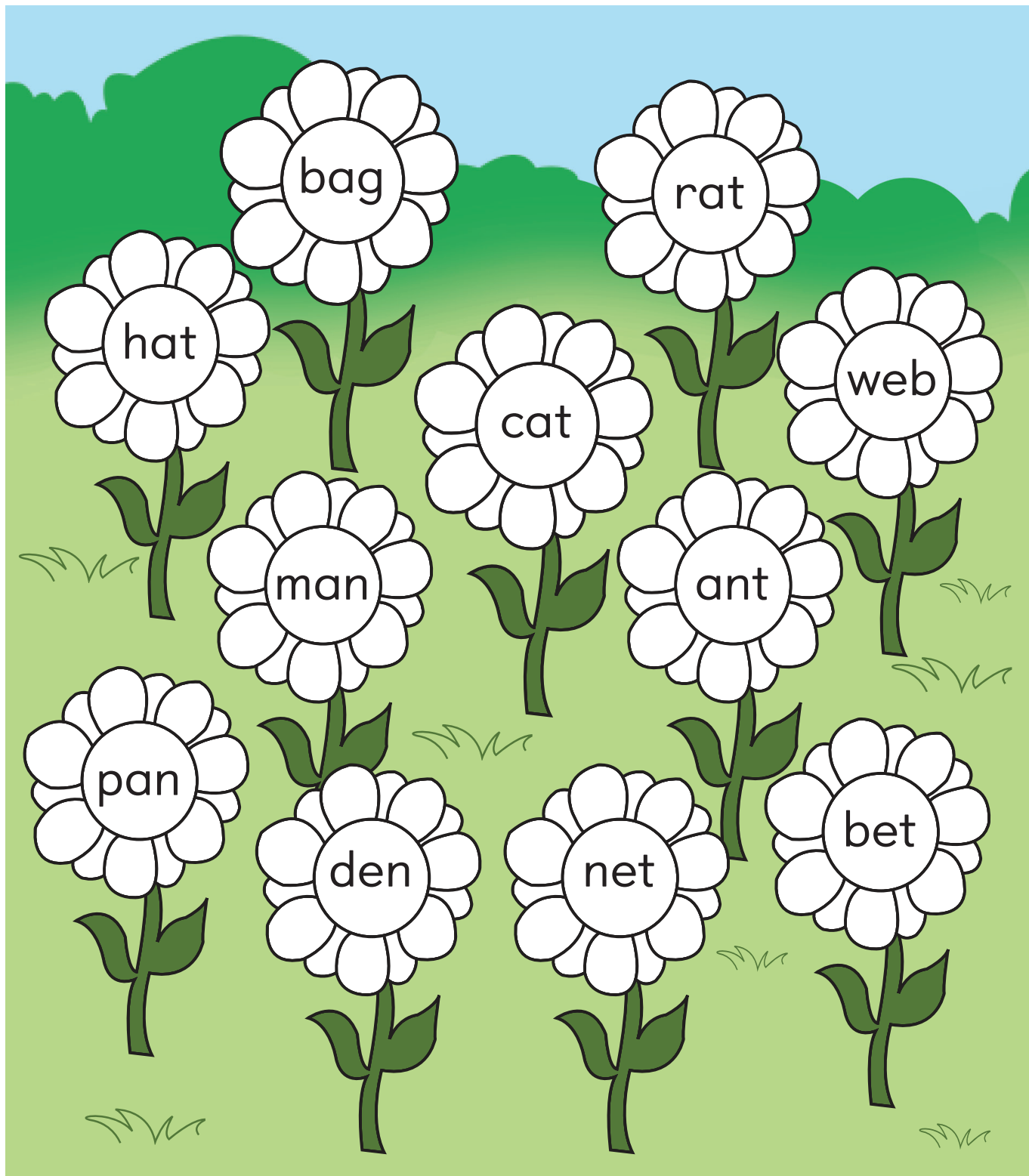

A sad lad.

Man has a bag.

Ram has a cap.

A brown cat.

The brown cat ate a bun.

A black rat.

The rat sat on a mat.

Dad in a car.



be

ate

but

are

am

black

brown

came

did

Family words - 'e'

_eb

web

_ed

bed

fed

led

red

_eg

beg

leg

peg

_em

stem

_en

den

ten

hen

yen

men

end

pen

_et

get

net

jet

pet

let

set

met

wet

yet

_es

yes

It's story time!

Prem and Dev



Little Prem got a new pen.



He went to school to meet his friends.



His friend, Dev, forgot his pen at home.



Dev felt sad.

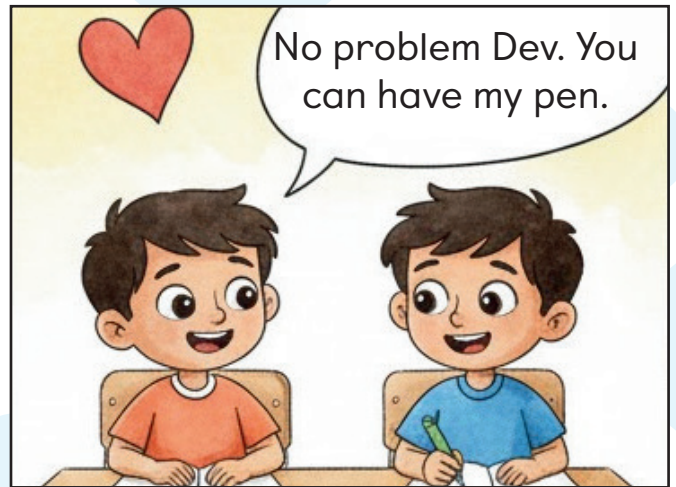

Dev was happy. Sharing makes us all great friends.



Have you helped your friends?

Make new words.

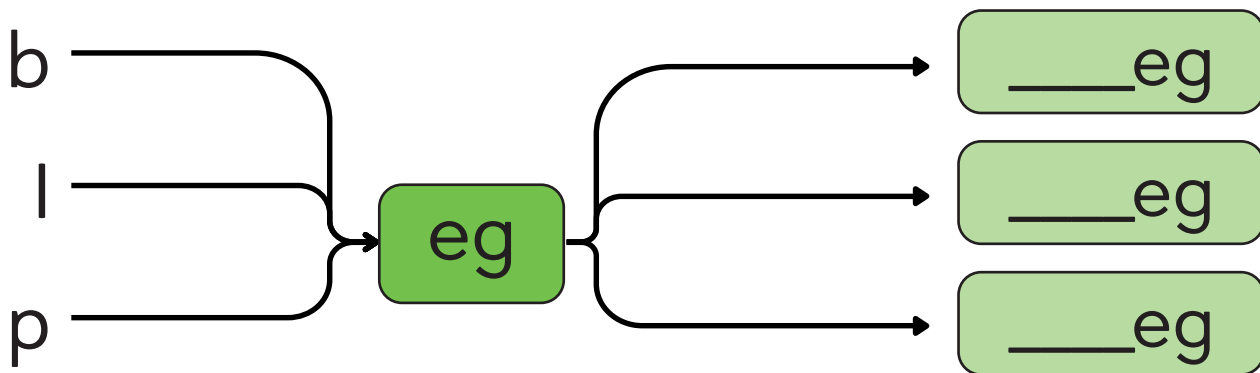
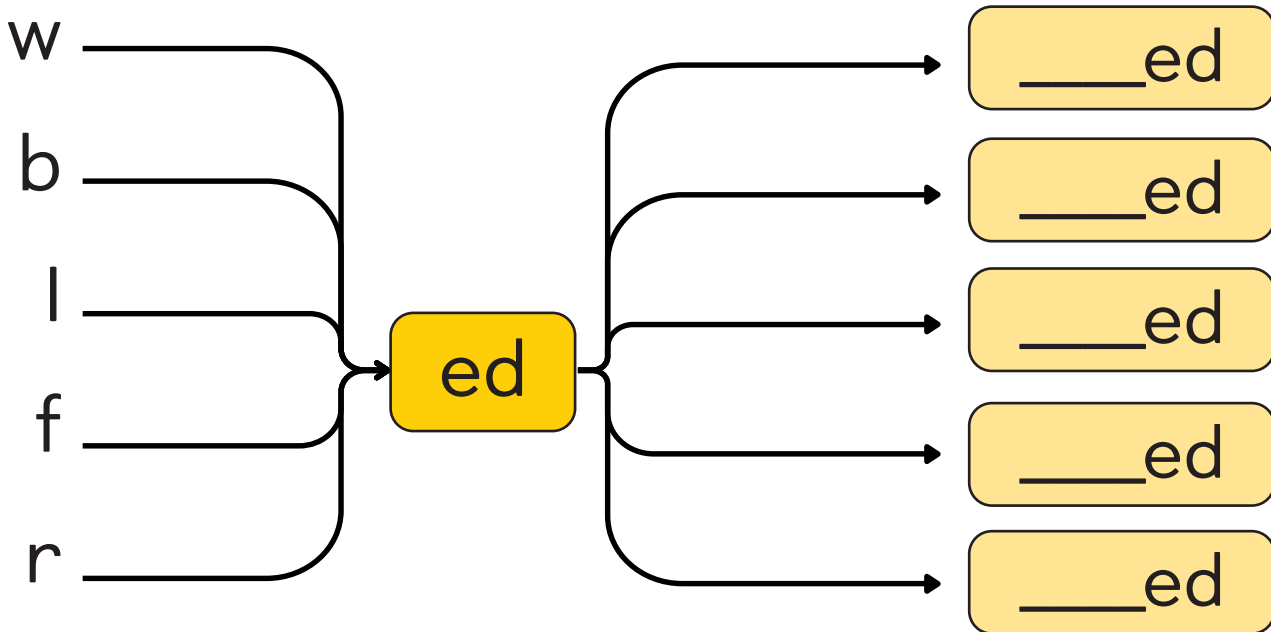

Make new words.

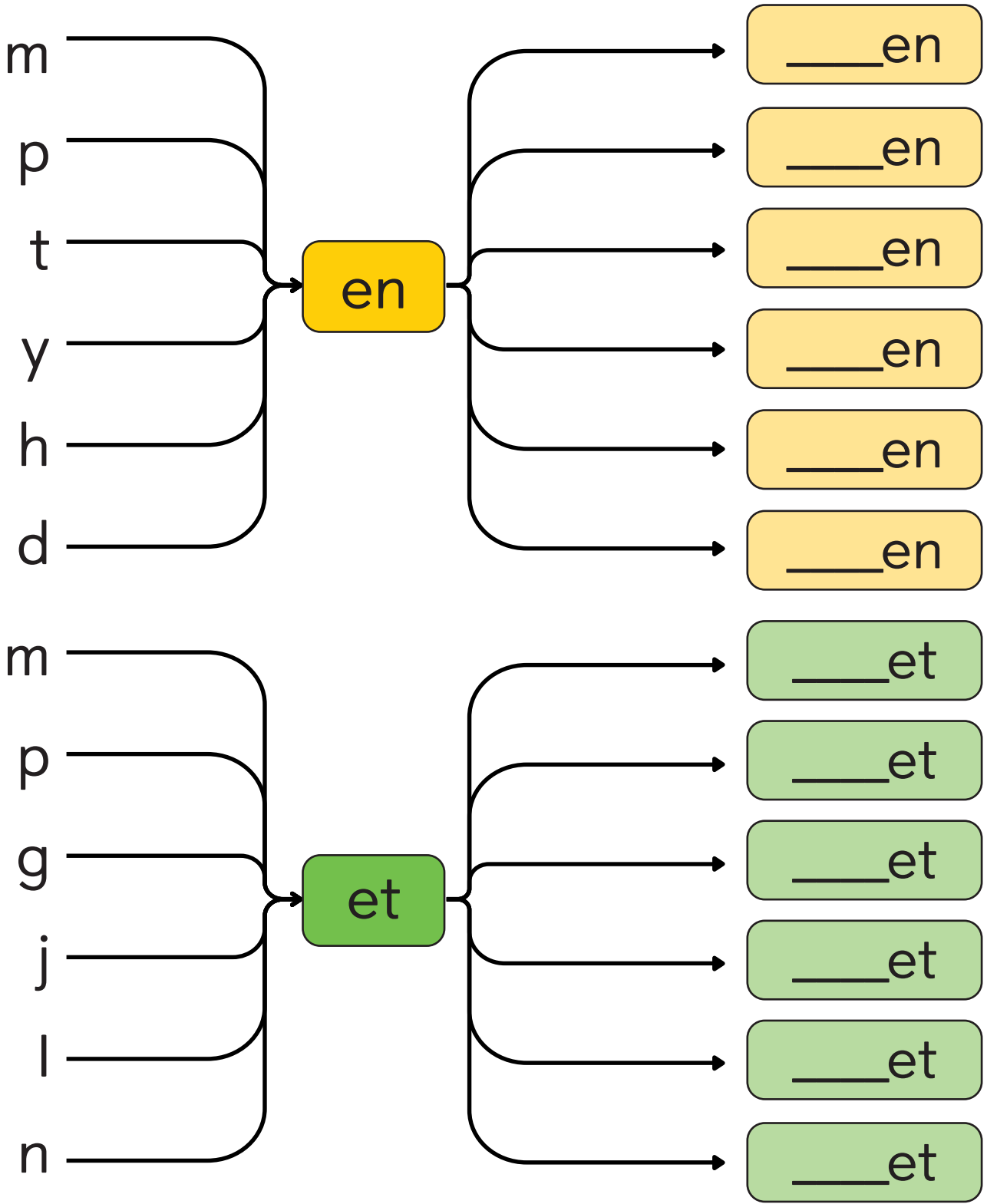

Family words



Read and circle.

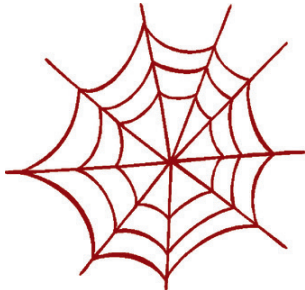

wet
bed
web
red

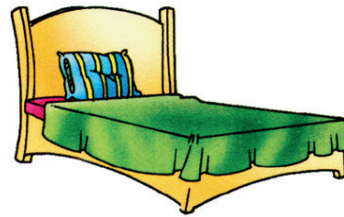

bed
led
fed
red



peg
beg
leg

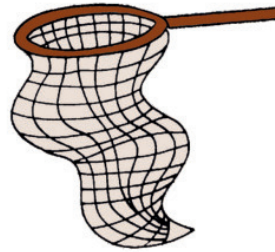

pet
yet
set
net



den
hen
men
end



get
let
jet
met



men
yen
hen
pen



men
ten
hen
pen



Colour the circles that have the letter 'e'

- he
- men
- pit
- hen
- ink
- pin
- fin
- end
- wet
- see
- fig
- pen
- web
- ten

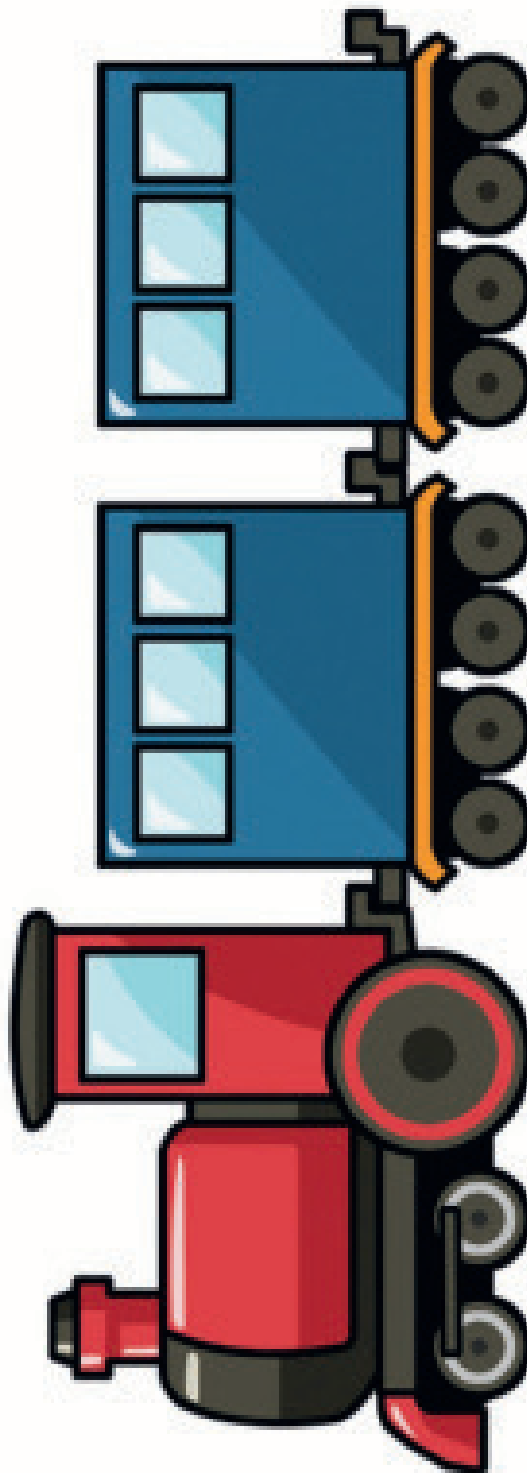

A red hen.

Four red hens.

I have a pen.

Get me a pen.

She is good.

See the bee.

See four bees on the tree.

A sheep in the pen.



get

he

four

like

eat

good

have

into

must

Family words - 'i'

_ib

bib

nib

rib

_id

did

hid

kid

lid

rid

_ig

big

dig

fig

pig

_im

dim

him

Family words - 'i'

_in

bin

fin

kin

pin

tin

win

_ip

dip

hip

sip

tip

_is

his

_it

bit

fit

hit

lit

pit

sit

wit

_ix

fix

mix

six

It's story time!

MILI'S CLASS ADVENTURE

Mili is in class. She opens her box - Oh no!

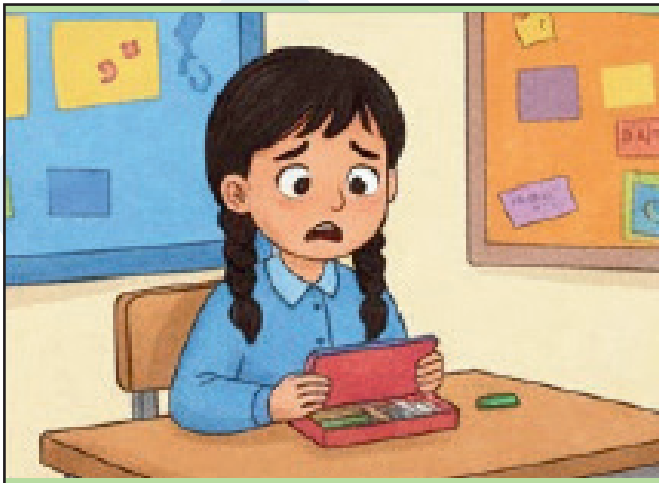

Her red crayon is missing.



"Did I drop it? Did I miss it?"



Rini, her friend, joins to help.



They look under the desk



Rini spots it near the bin.

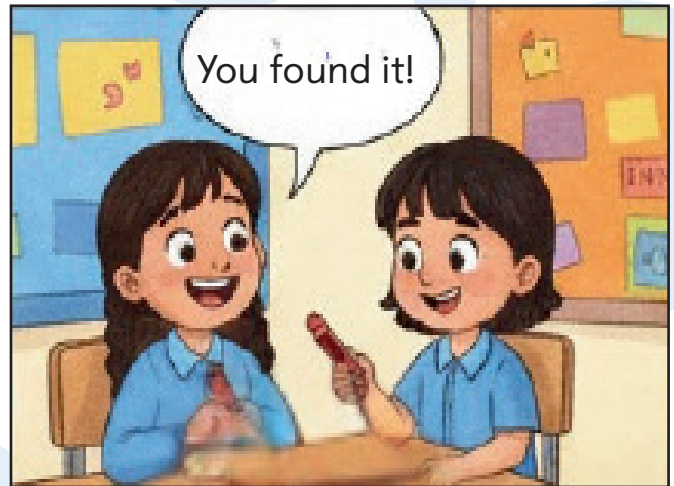

Mili grins. "You found it".

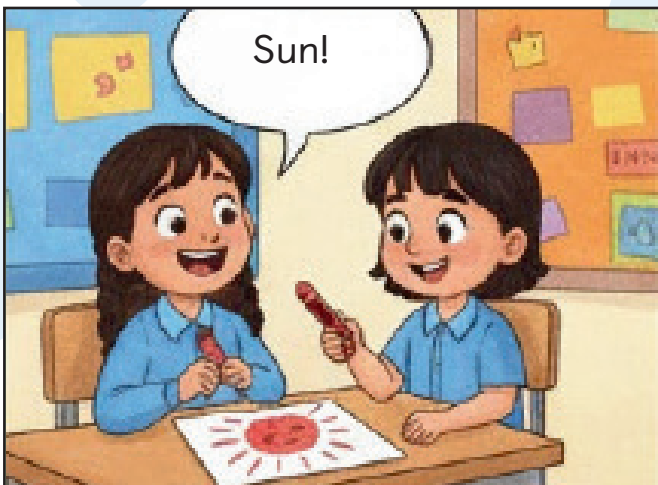

They sit and draw — a big red sun.



Mili smiles, "To help is to win".

Have you lost and found something?

Make new words.

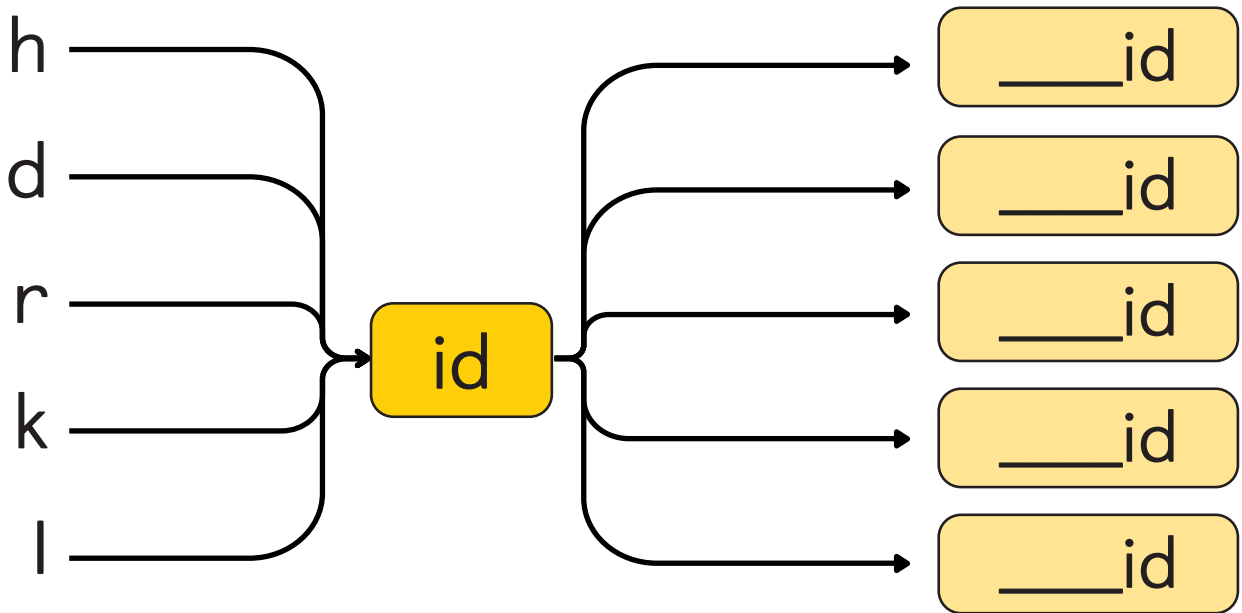
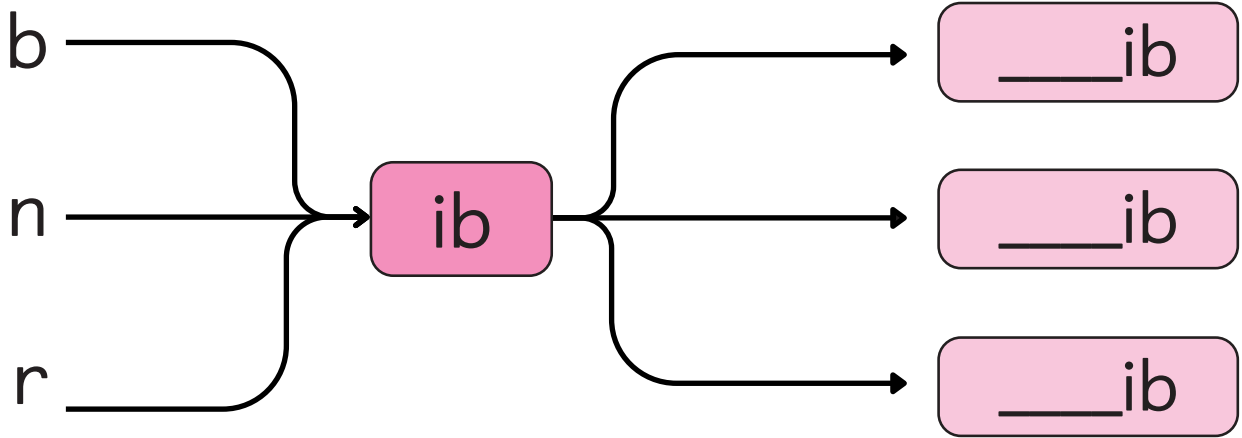

Make new words.

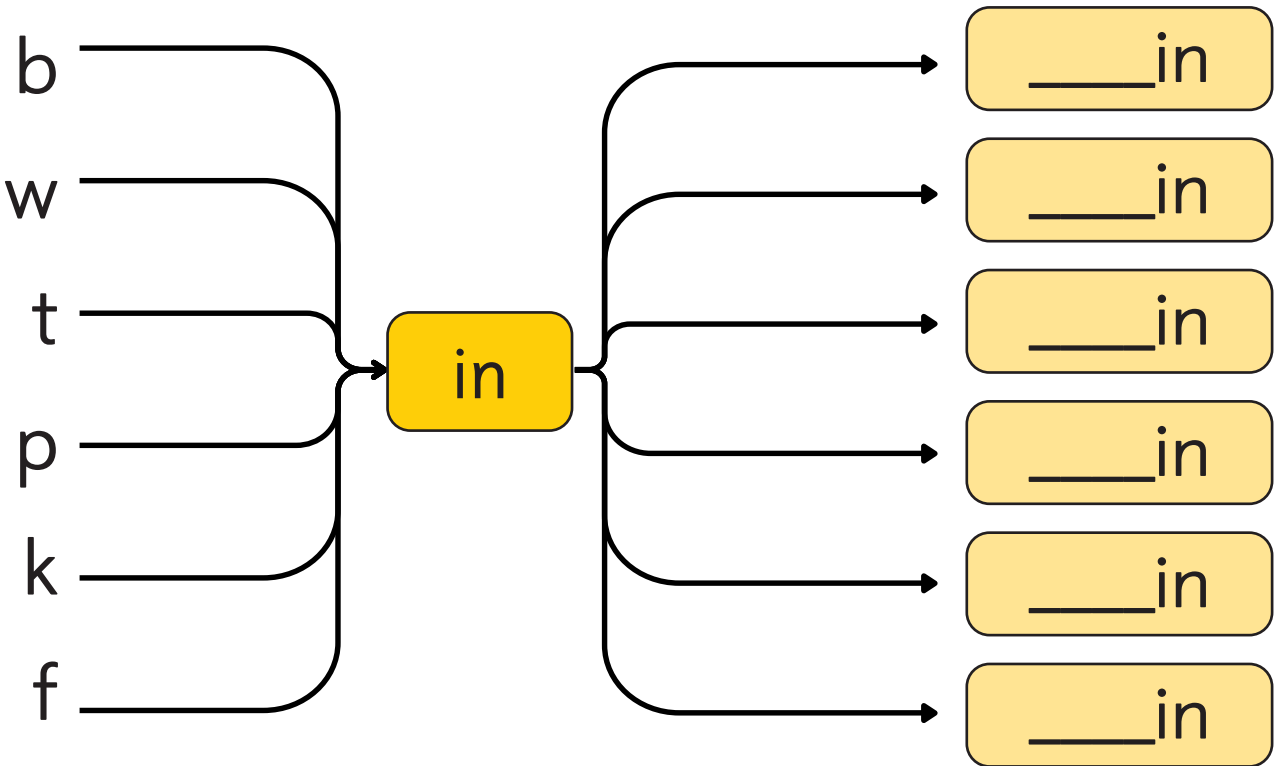
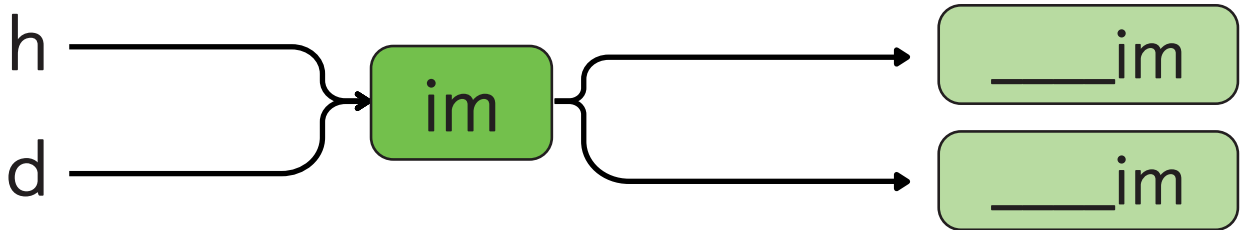
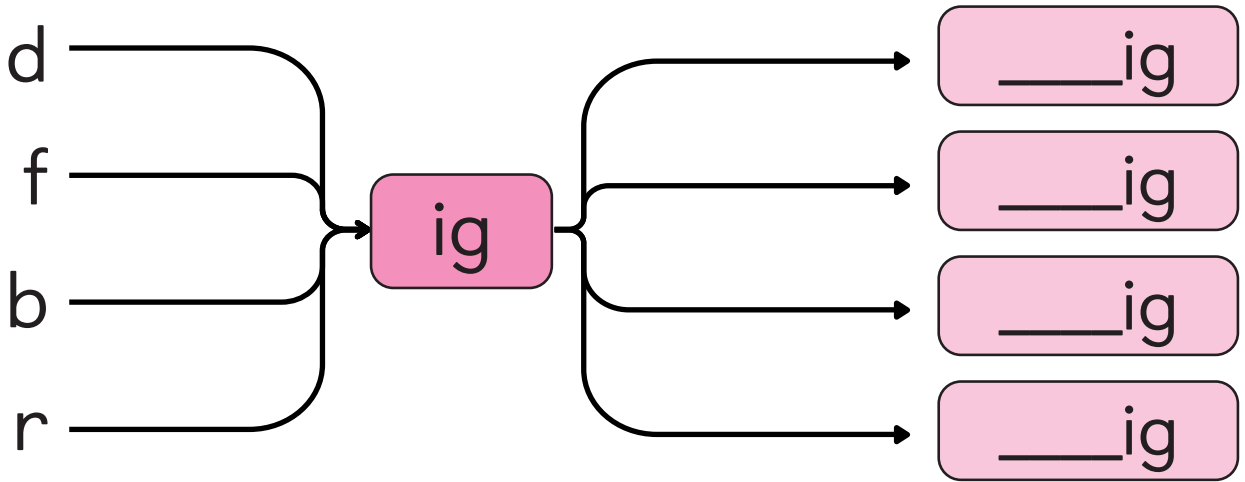

Make new words.

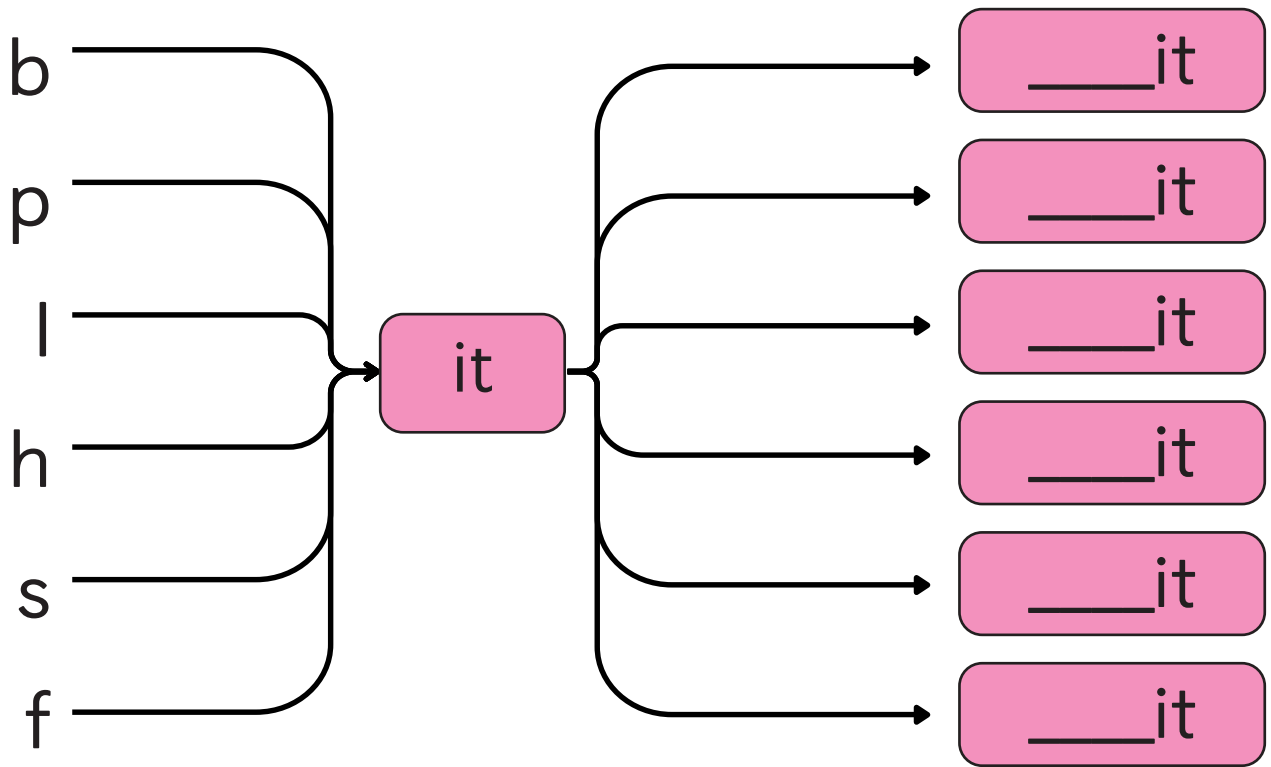
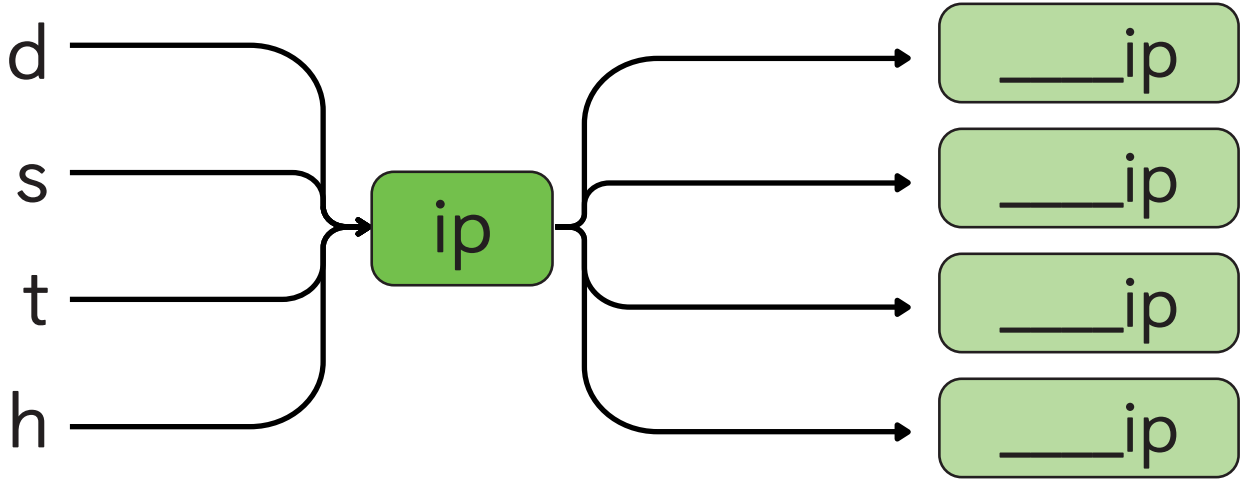

Family words



Listen and circle.

bib nib
rib crib

did hid
kid lid

bin kin
pin fin

big pig
dig fig

dip sip
hip tip

Family words



Colour the kites that have letter 'i' in them.

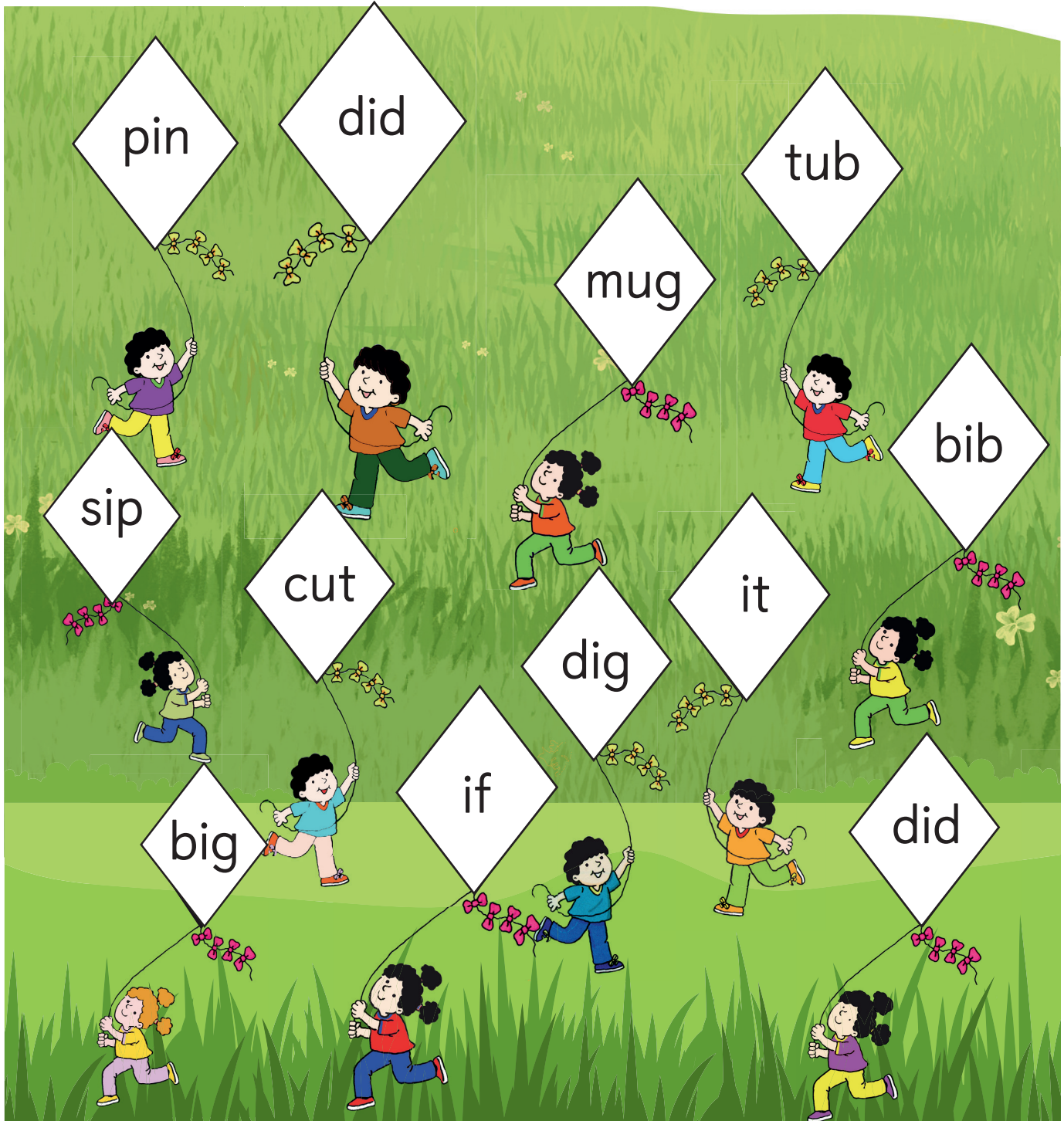

See the kid run.

A pin in the bin.

A pig in the pit.

A new pen.

Six men and ten kids.

Kid with a pen.

Please come in.

My mother is pretty.



our

out

on

ran

now

please

pretty

new

ride

Family words - 'o'

_ob

job

mob

rob

sob

_od

cod

nod

pod

rod

_og

dog

fog

hog

jog

log

Family words - 'o'

_op

c**o**p

h**o**p

m**o**p

p**o**p

t**o**p

_ot

c**o**t

d**o**t

g**o**t

h**o**t

j**o**t

l**o**t

n**o**t

p**o**t

_ox

b**o**x

f**o**x

It's story time!

THE MISSING SOCK!



It is nine o'clock.
Father must go to office.



Only one sock is there.
Where is the other one?



Father hops "Oh no! Where is
my sock?" Mili giggles.



Mili points to the mop.
"Your sock is on top of the
mop", she says.



Father grins. "Thank you, my smart kiddo."



Happy father and his smart kiddo!

Can you remember any silly or funny thing that happened at your house?

Make new words.

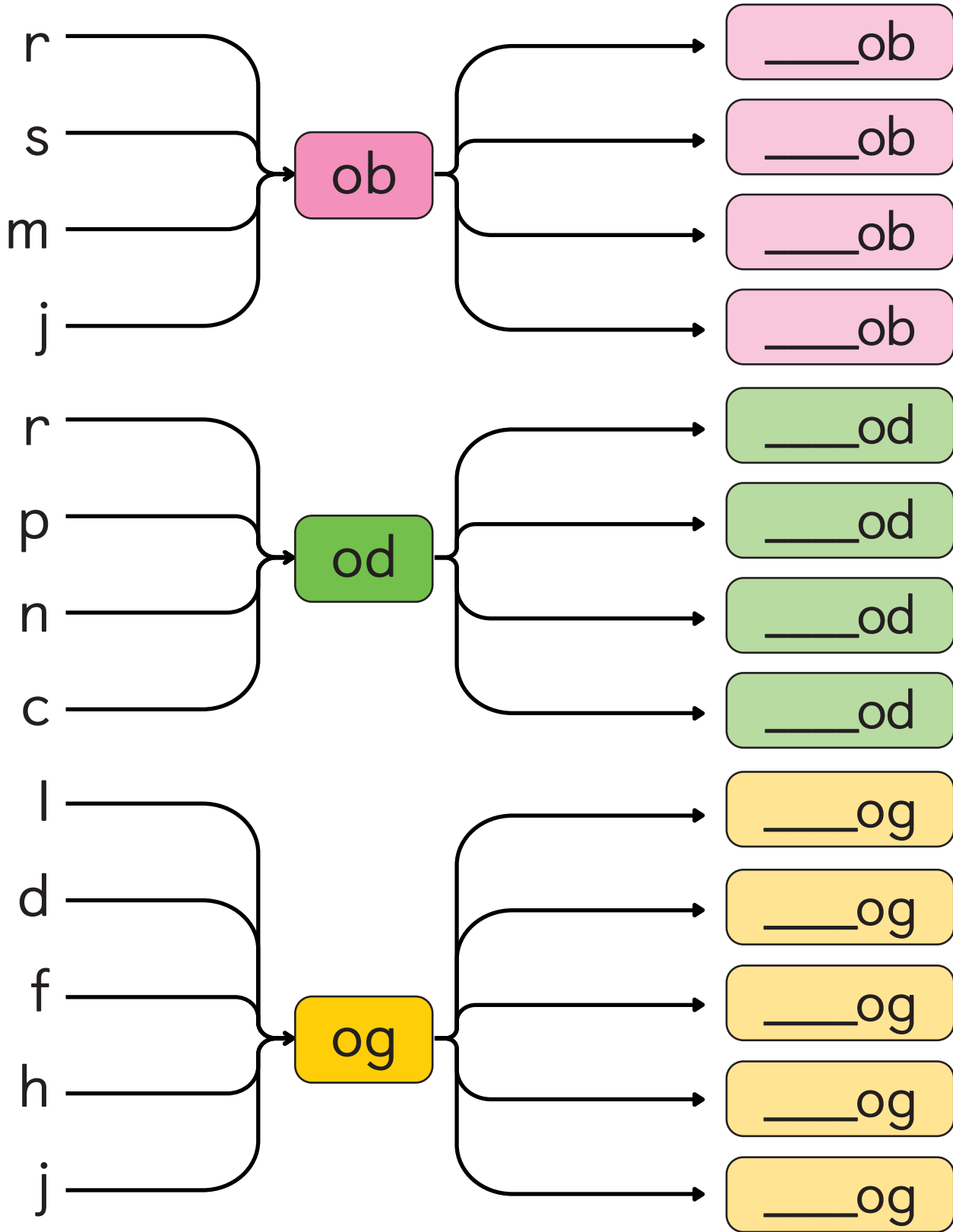

Make new words.

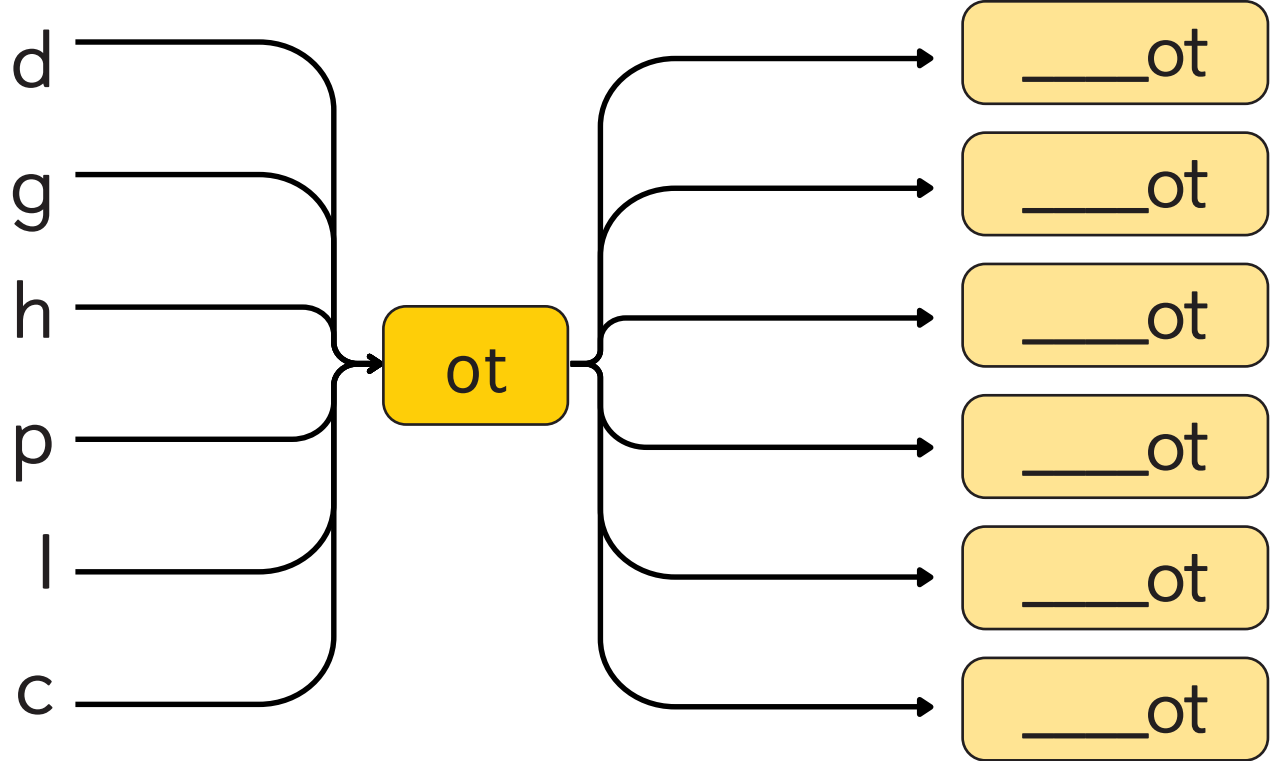
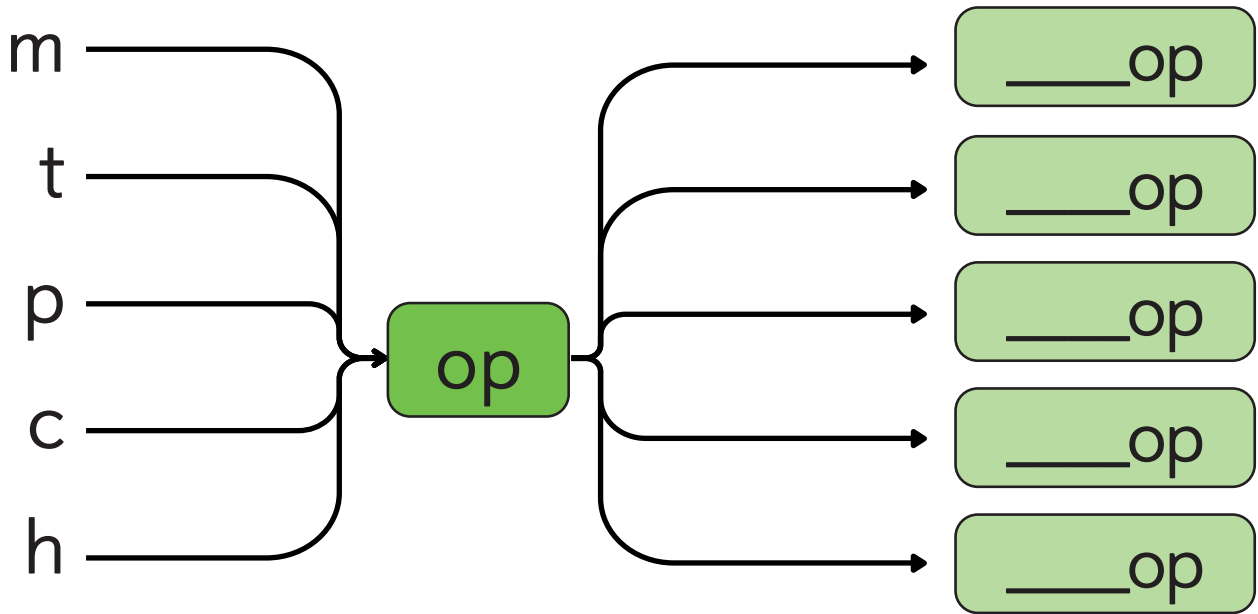

Family words



Circle the correct word.



job
mob
rob
sob



cod
pod
nod
rod



peg
beg
dog
leg



got
hot
lot
jot

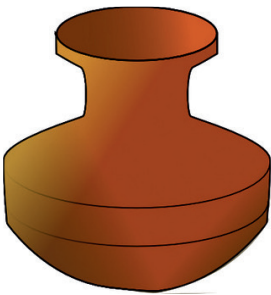

pot
got
lot
not



cop
mop
hop
pop

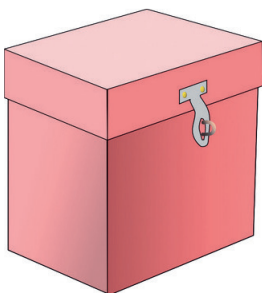

box
fox
of
on

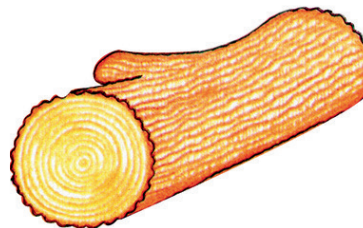

log
hog
jog
dog

Family words



Draw lines to match each bee with the flowers that have the same word

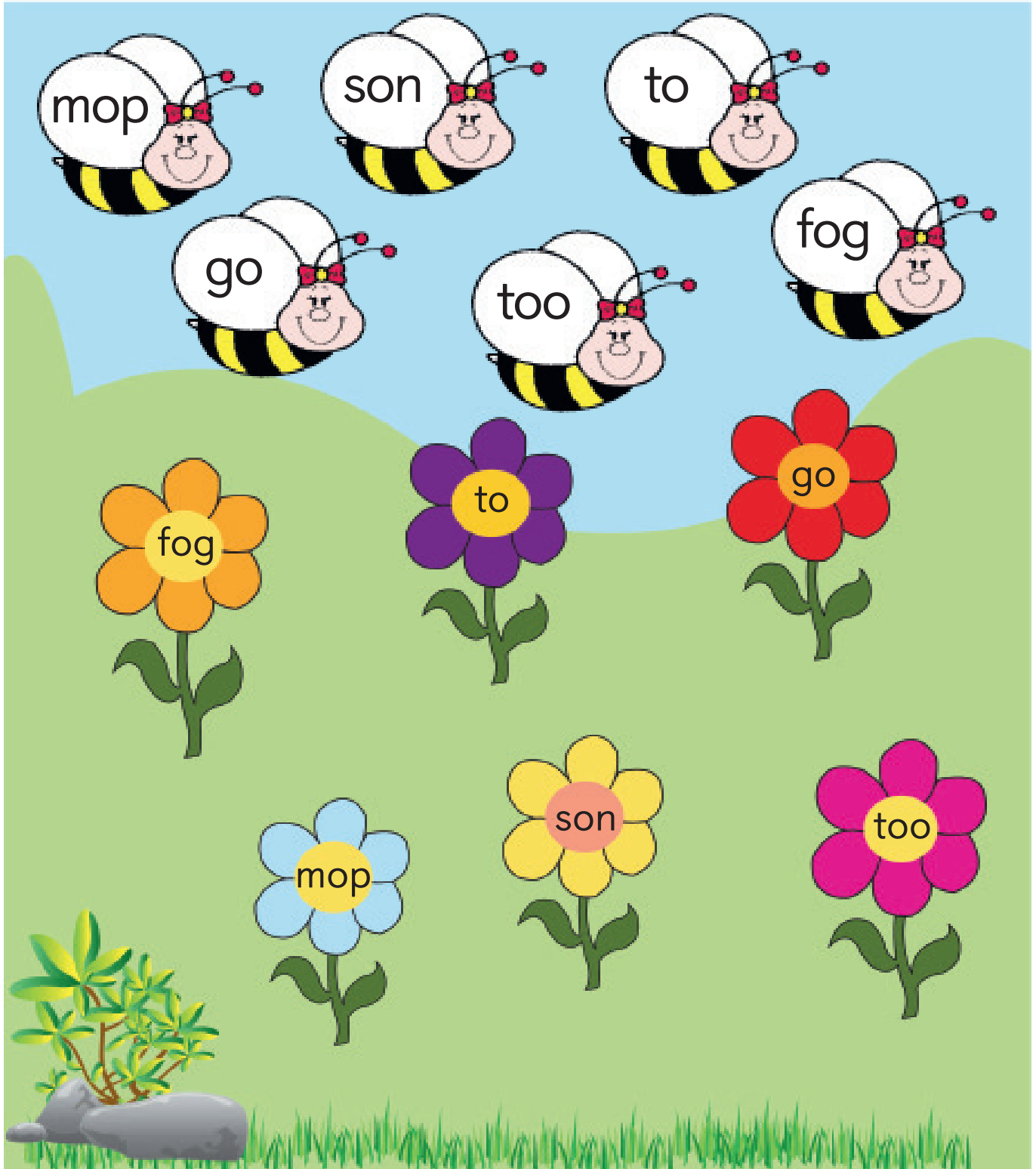

This is a pot.

The pot is hot.

That is a big box.

There is a pin in the box.

There is a big den.

The fox is in the den.

She saw a dog.

They sat on the mat.



soon

that

saw

they

she

there

this

too

say

Family words - 'u'

_ub

cub

hub

rub

tub

_ud

bud

cud

mud

_ug

bug

dug

hug

jug

mug

rug

tug

_um

gum

hum

sum

Family words - 'u'

_un

bun

fun

gun

run

sun

_up

cup

pup

_us

bus

_ut

but

cut

hut

nut

Rainy Day



Cuba the cub woke up on a Sunday morning. It was raining.

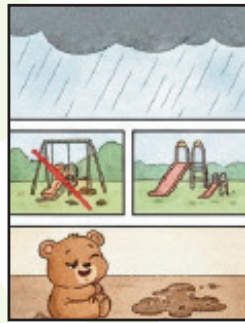

"Oh no! No Sun! I cannot run, I cannot jump in the park" he said.



Cuba sat on his rug



Cuba's mother asked, "Why are you so grumpy, Cuba?"



"Why don't you drum?" she said.

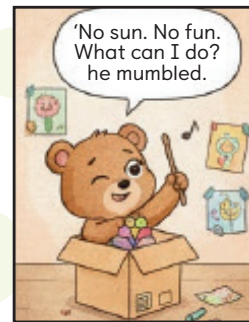

Cuba began to drum.



Cuba began to tap the drum and hum a fun tune.



Cuba wasn't grumpy anymore. He was one happy cub with a big grin!

What do you do on a rainy day?

Make new words.

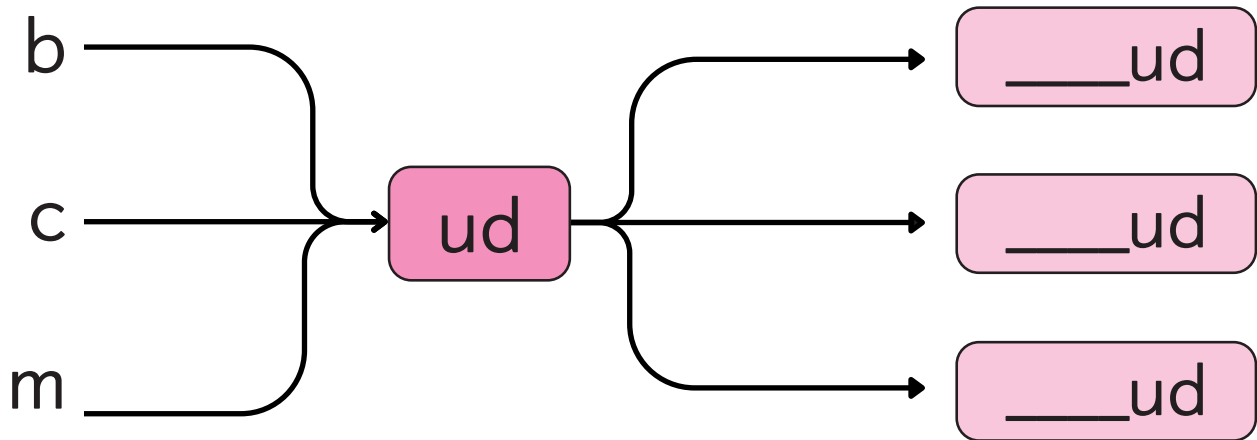
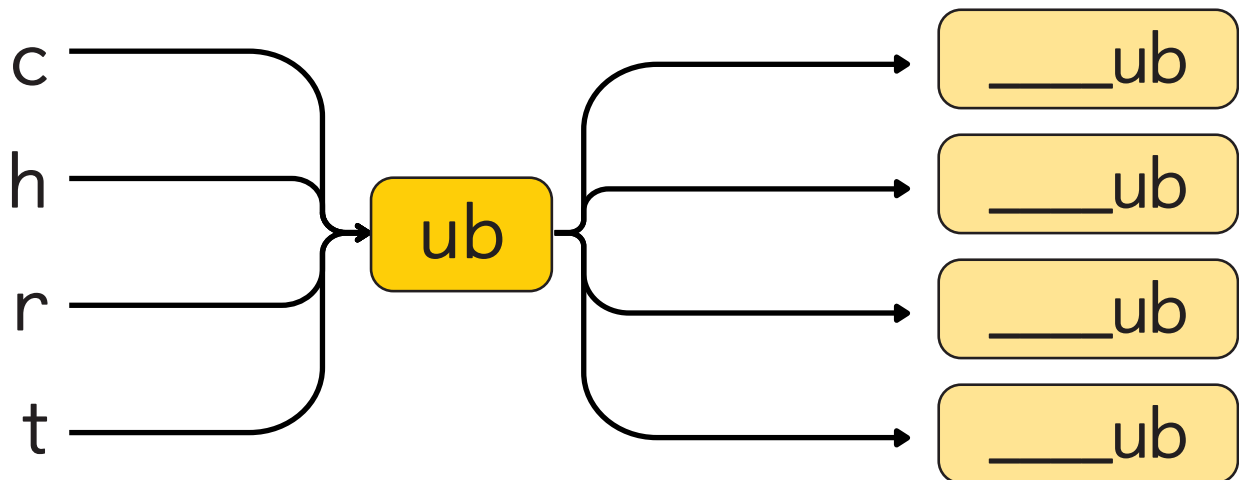

Make new words.

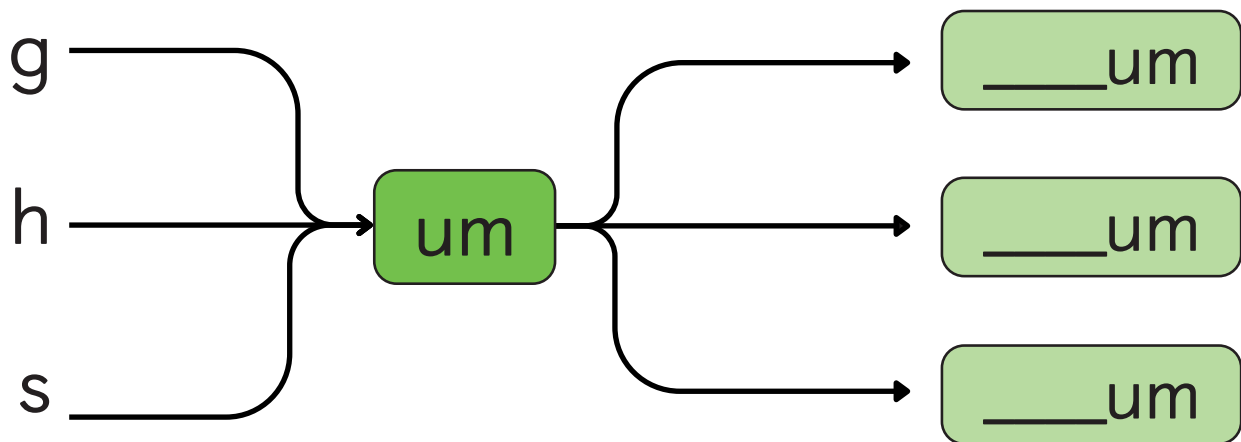
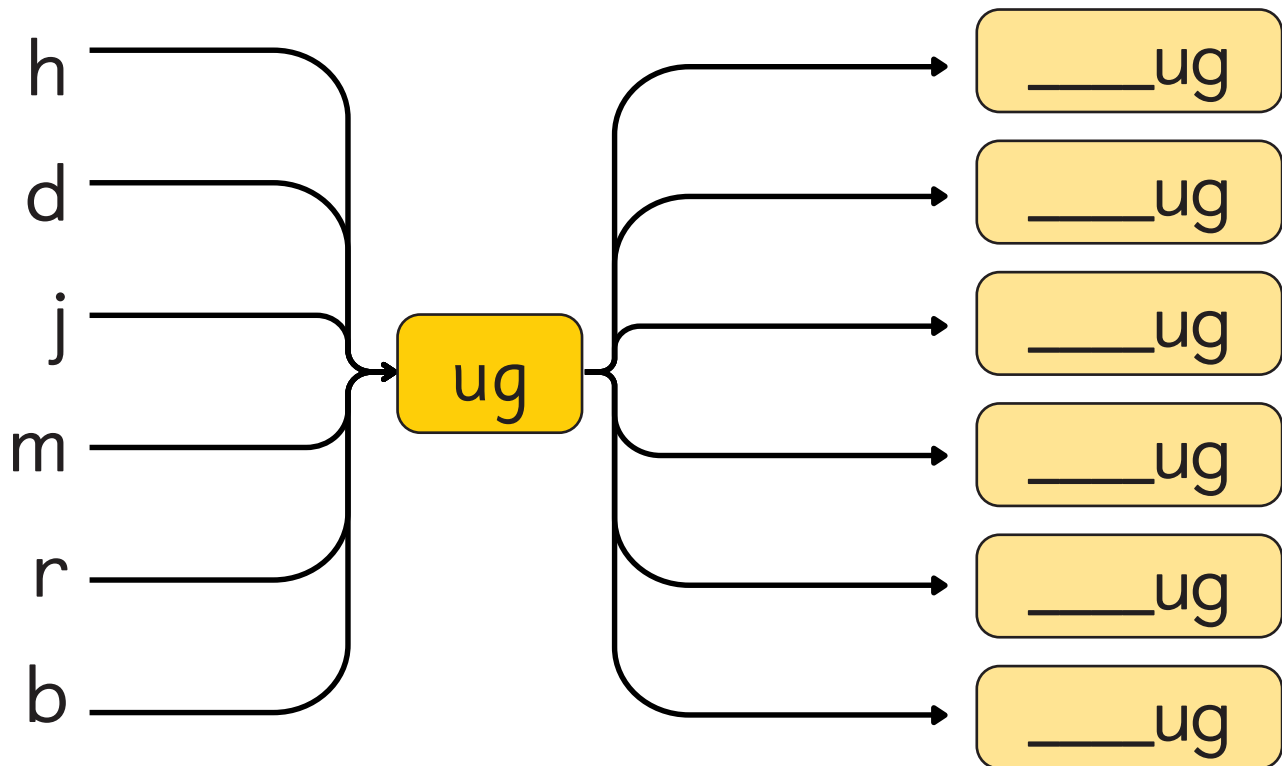

Make new words.

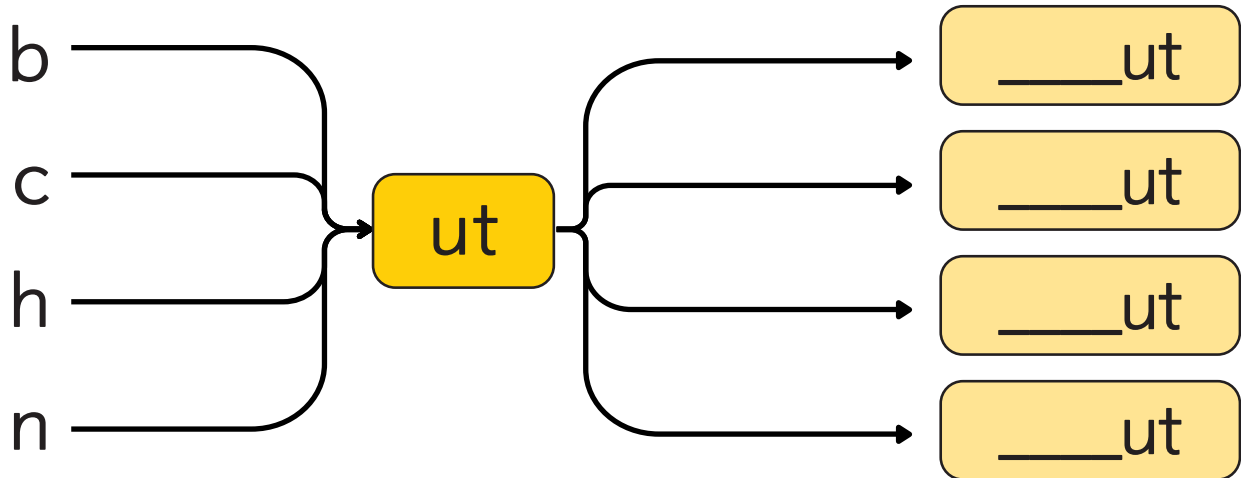
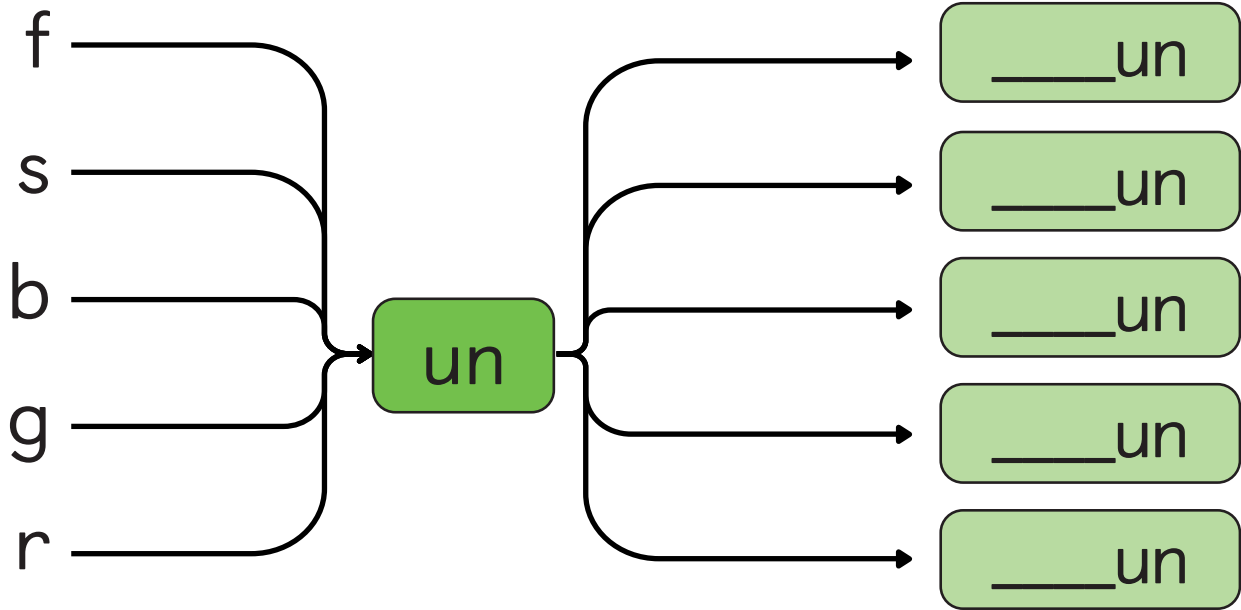

Family words



Circle the correct word.



tub
hub
rub
cub

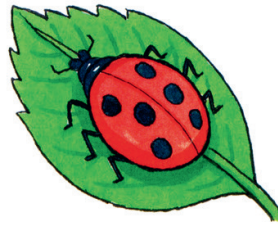

hug
dug
jug
bug



cup
but
pup
cut

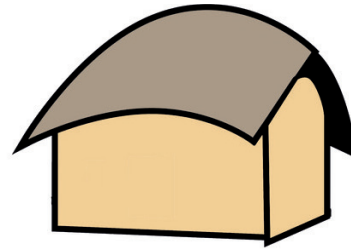

cut
but
nut
hut

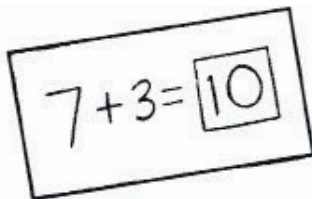

gum
hum
sum
gun



gun
sun
fun
run



cut
but
nut
hut



cut
but
pup
bus



Colour the planets that have letter 'u'.

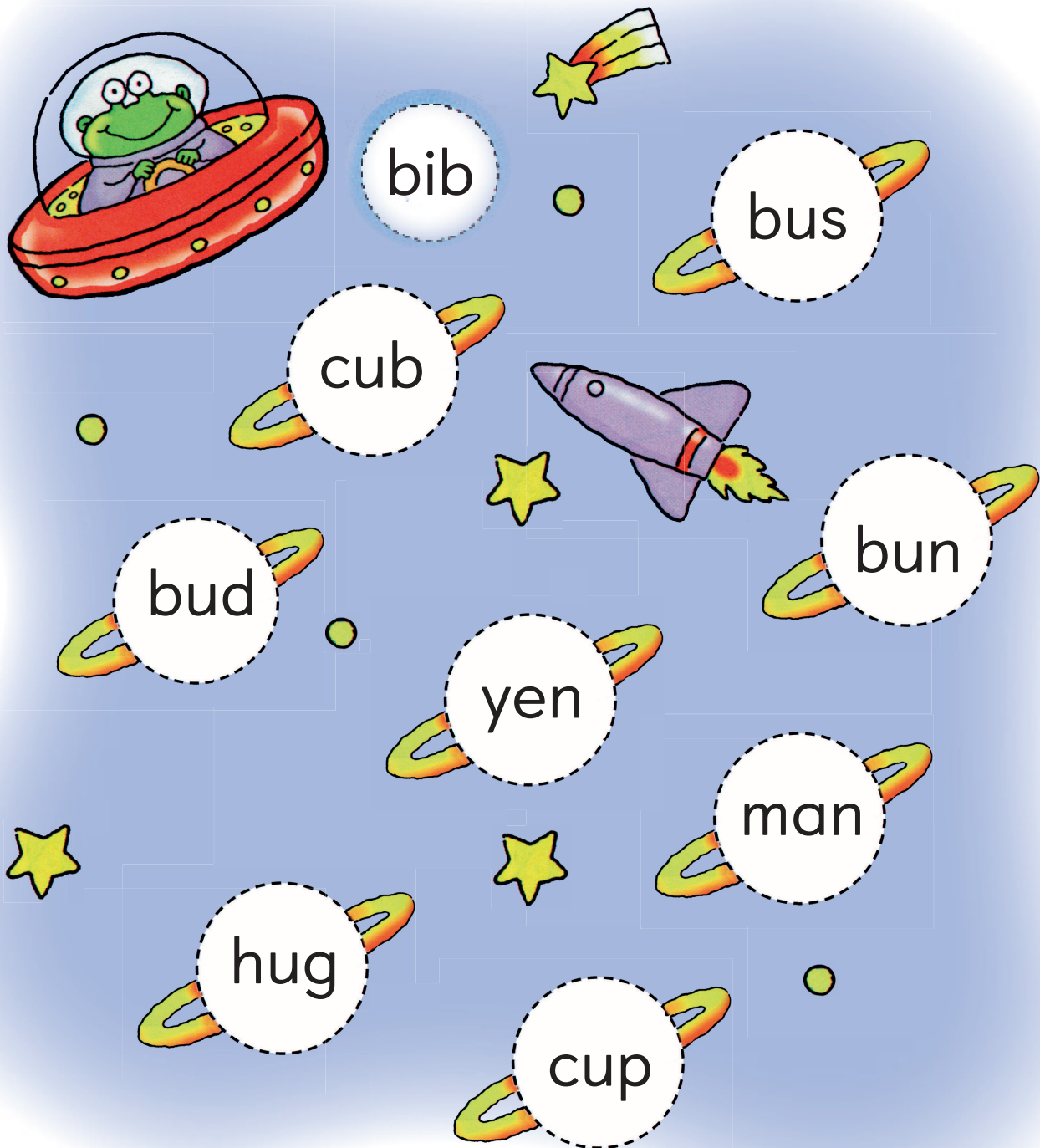

Family words

Match the words in the cloud to the rhyming words in the puddle .



I want a bun.

What is in the jug?

Who is in the den?

Three cubs are in the den.

Bug is under the rug.

The pup is white.

Yes. It is hot.

Fox is in a hut.



what

well

who

will

want

white

under

with

yes

Recap

Colour the rhyming words.

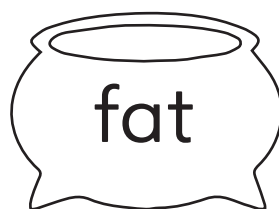
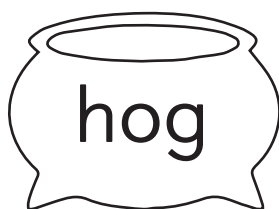
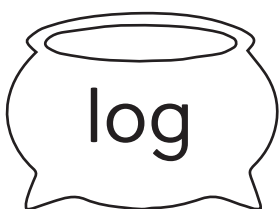
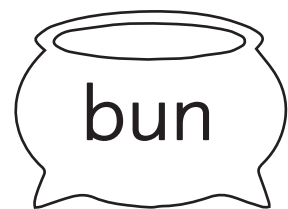
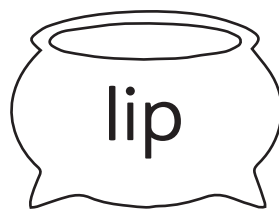
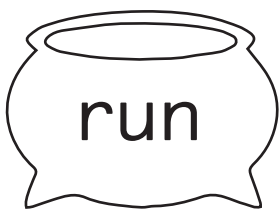
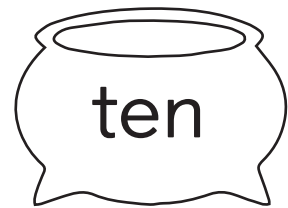
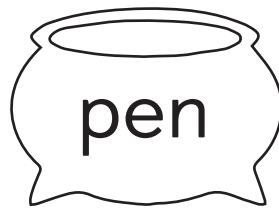
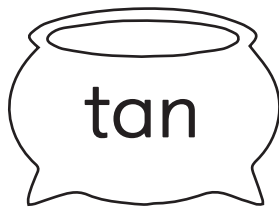
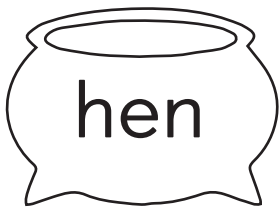
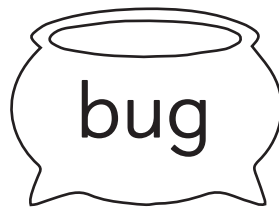
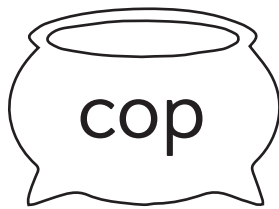
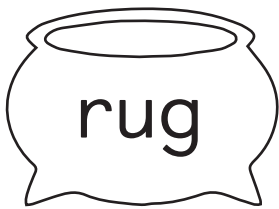
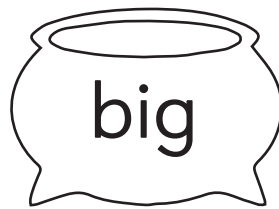
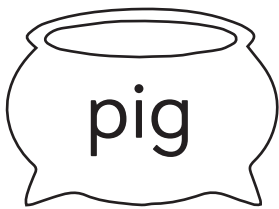
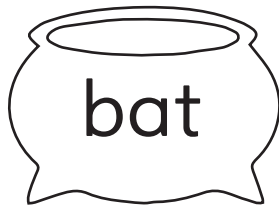
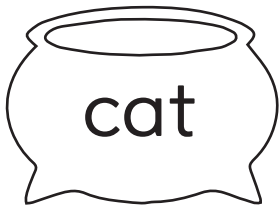

Recap

Fill in with vowels (a/e/i/o/u) .

l ___ d

f ___ n

j ___ r

b ___ g

p ___ g

h ___ n

___ nd

y ___ k

d ___ y

v ___ n

p ___ n

h ___ p

l ___ d

m ___ x

c ___ t

f ___ x

s ___ n

b ___ ll

Recap

Fill in the blanks.

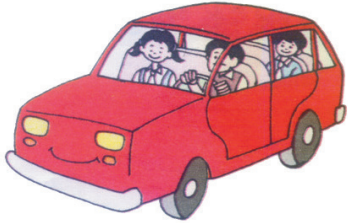

The _____ is red.

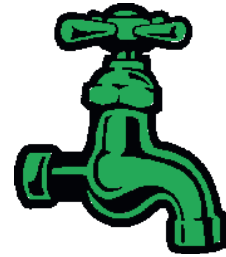

The _____ is green.

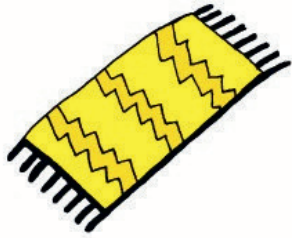

The _____ is yellow.

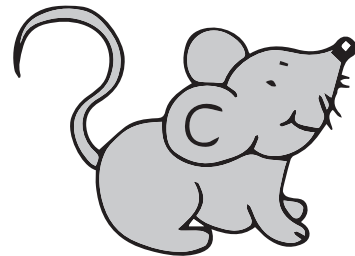

The _____ is grey.



The _____ is blue.

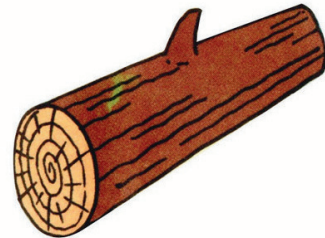

The _____ is brown.

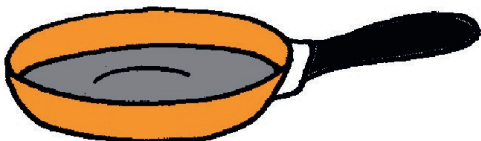

The _____ is orange.



The _____ is black.

Recap

Fill in the blanks.

The  _____ is **red**

The  _____ is **orange**

The  _____ is **purple**

The  _____ is **green**

The  _____ is **brown**

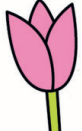
The  _____ is **pink**

The  _____ is **blue**

The  _____ is **yellow**

The  _____ is **black**

The  _____ is **white**

Recap

Name the pictures.





10





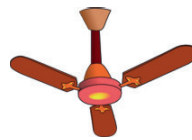



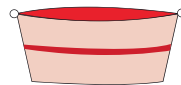









Recap

Circle the pictures that have the same sound in each group.

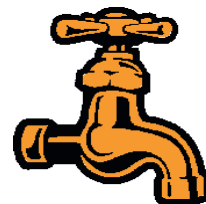
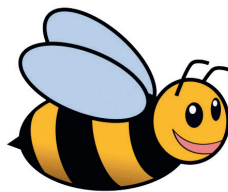
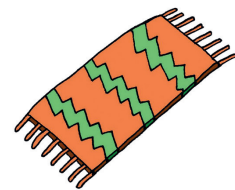
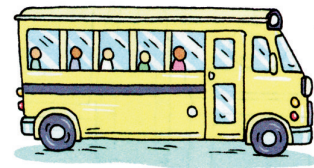
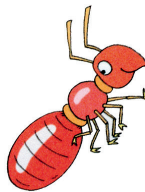
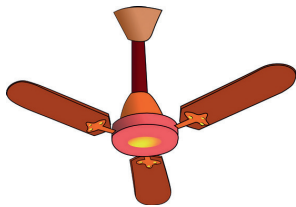
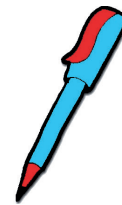
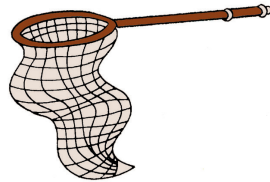
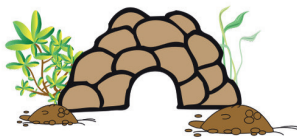
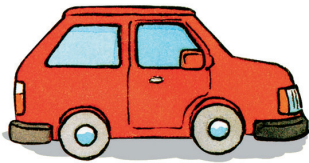

Shila loved to play outside. One sunny morning, she was building a tall sandcastle near her home. Her hands were covered in sand and dirt.

"Lunchtime, Shila!" her mother called from the kitchen.

Shila ran inside, excited to eat.

But her mother stopped her. "Wait, Shila! Before you eat, what should you do?" Shila looked at her sandy hands and knew just what to do!

"Yes I know mother. I must wash my hands."



Do you wash your hands before and after eating?

Let's learn some new words and fill the empty box with a new word.

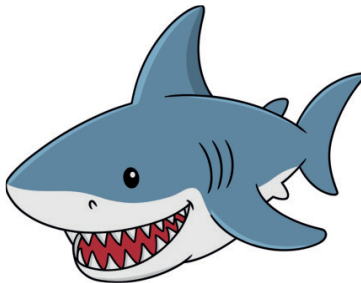

shark



shell



shapes

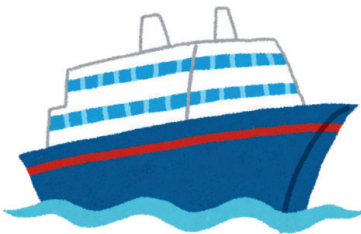

ship

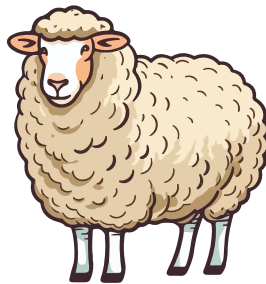

sheep



shirt



shower



shorts

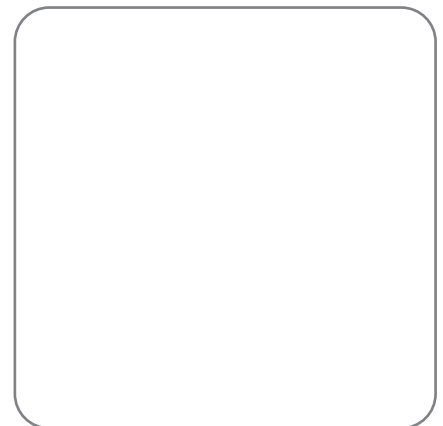

Fill in with 'sh'

_____ ip

_____ ark

fi _____

_____ ell

_____ irt

_____ apes

_____ oes

_____ orts

Let's read!

Sheela is a little fish.

Shenba is a crab.

Sham is a frog.



Shenba and Sham play together
on the shore.

They found a shell.

Shenba and Sham share the shell with
Sheela. They are happy.

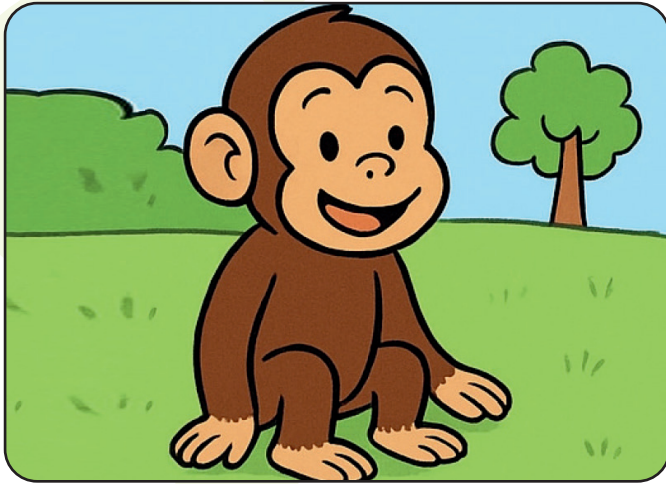

Chip the chimp finds a big red chair in the park. "Wow! A comfy chair!" he says.

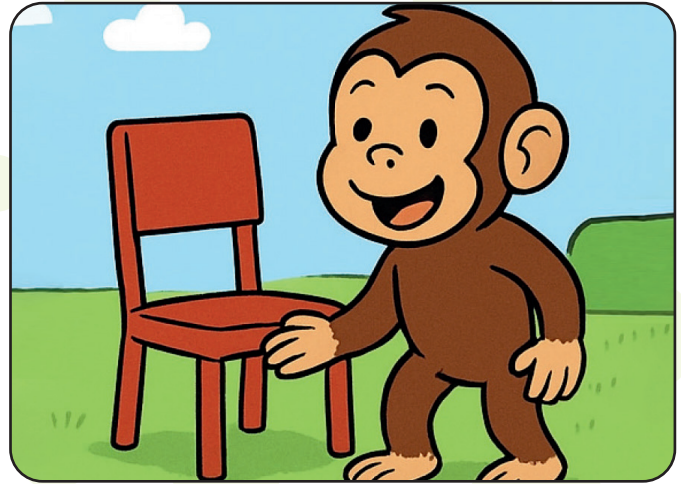

I want the chair too!

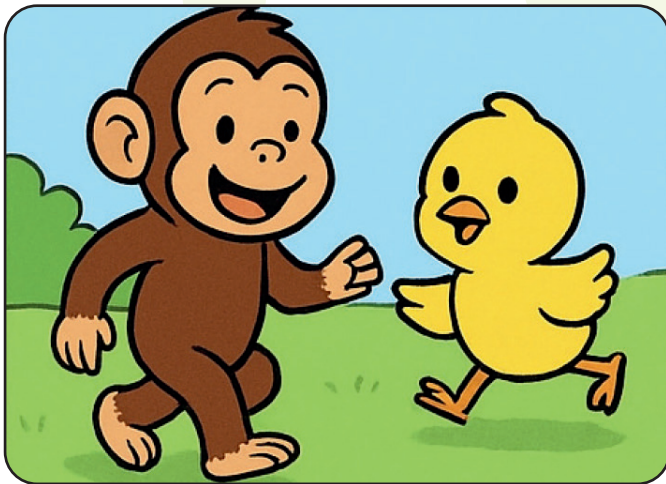

The chick and Chip play and chase each other around the chair. They laugh and have fun.

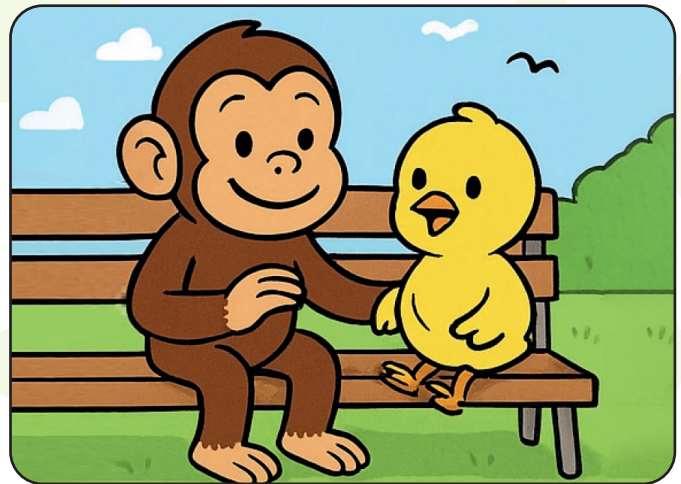

At last, they sit together. 'We can chat and chill!' says Chip.

Do you give up your favourite chocolate for your friend?

Let's learn some new words and fill the empty box with a new word.



chain



chick



cheese



chair



bench



watch



peach

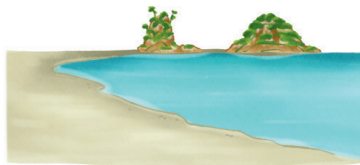

beach

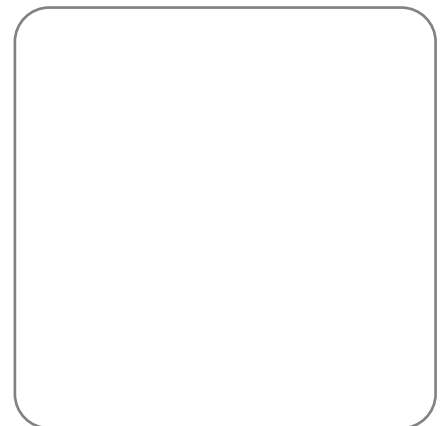

Fill in with 'ch' to complete the word.

bun__

ar__

lun__

Add 'ch' to complete the words and then read them aloud.



mun__

pin__

pun__

ben__

bun__

lun__

ch

ch

__ap

__at

__ip

__in

__op

Find and circle the 'ch' words.

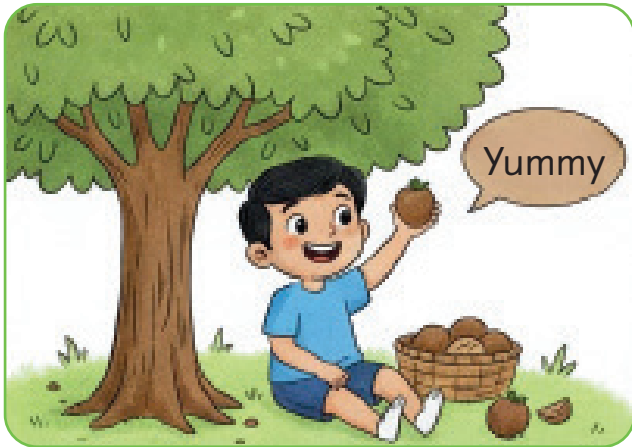

Chintu loves to munch.



Chitra likes to chant.

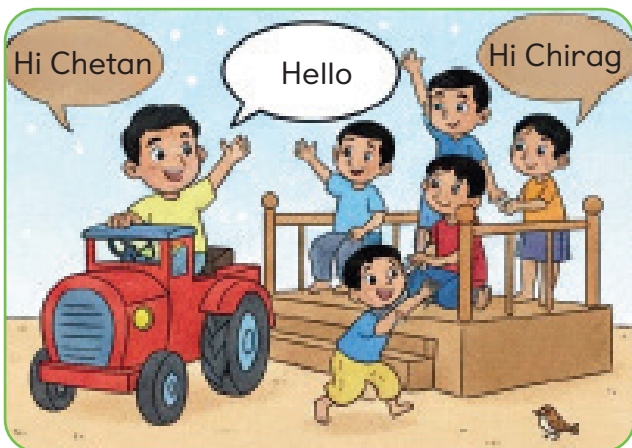

Chirag likes to chat.

Circle ch or sh?



ch
sh



ch
sh

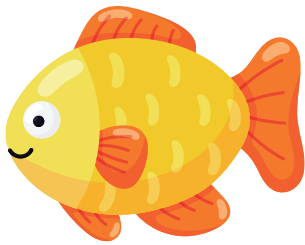

ch
sh



ch
sh



ch
sh



ch
sh

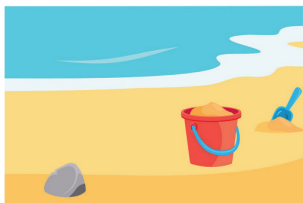

ch
sh



ch
sh

It's story time!

The Three Pots

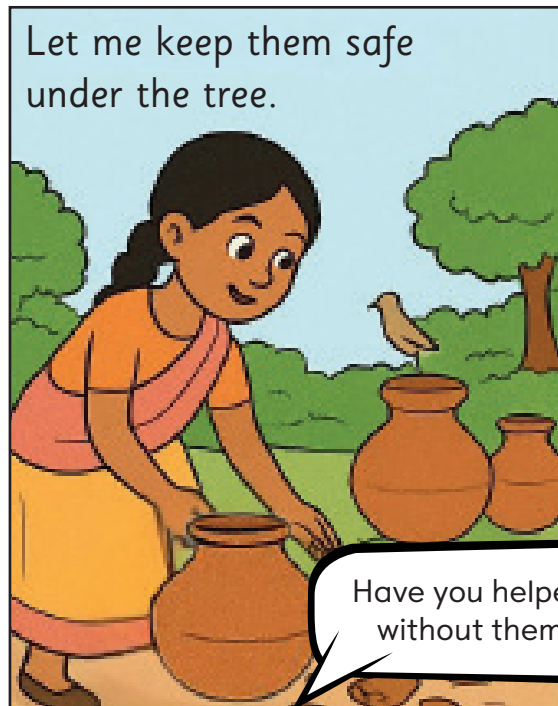
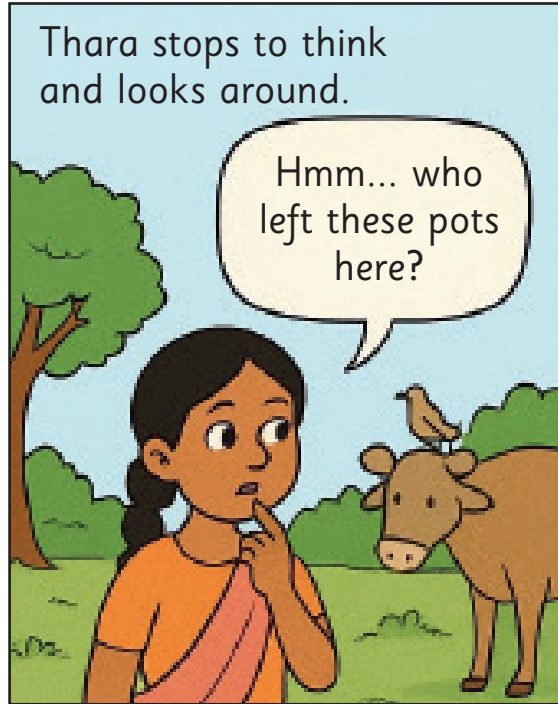
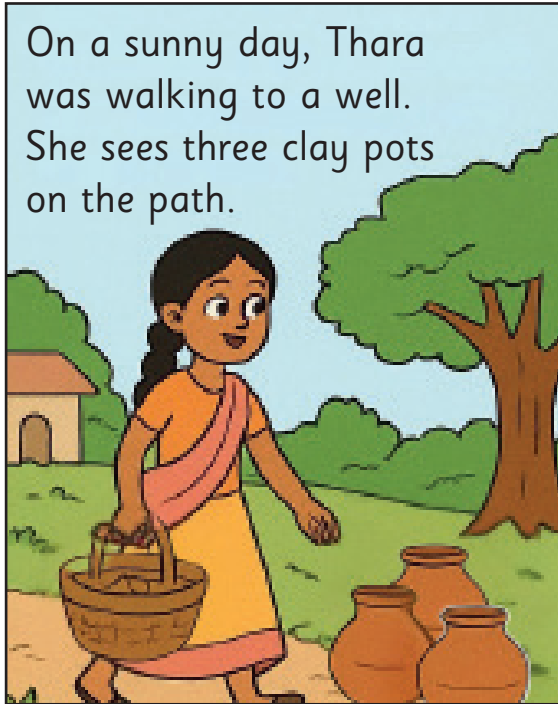

Let's learn some new words.

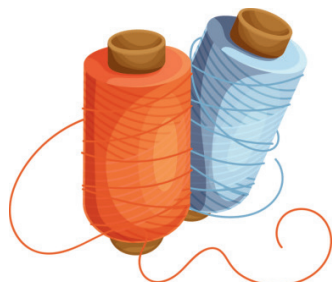

thread



three



thumb



thunder



Earth



bath



tooth



mouth

Add 'th' to complete the words and then read aloud.

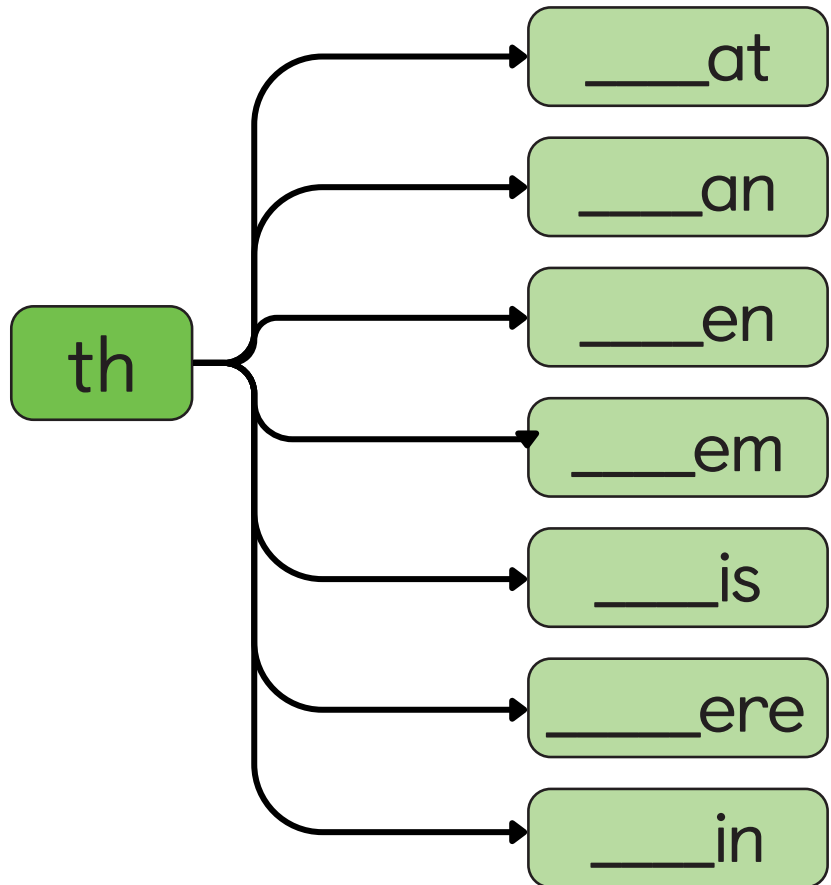
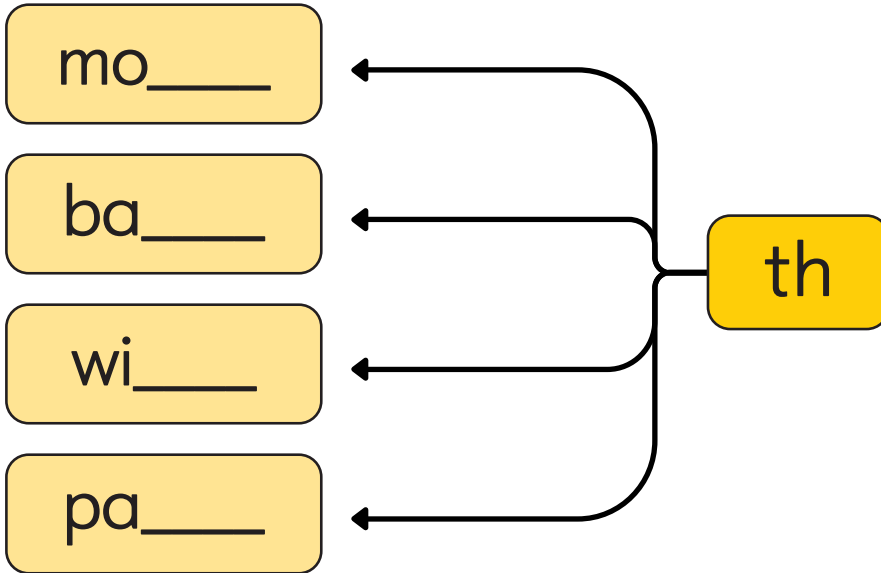

Let's read!



Thyagu thinks, "What to play?"



He had three colourful toys.



He played with the kite in the sun.



His mother made a delicious dish.



Thyagu loves his toys.



He is thankful to his family.

What are you thankful for?



Match

Match



three



sh

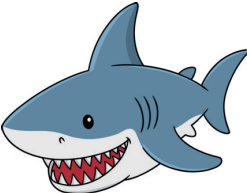

shark



ch



sheep



th



thief



sh



chick



th

It's story time!

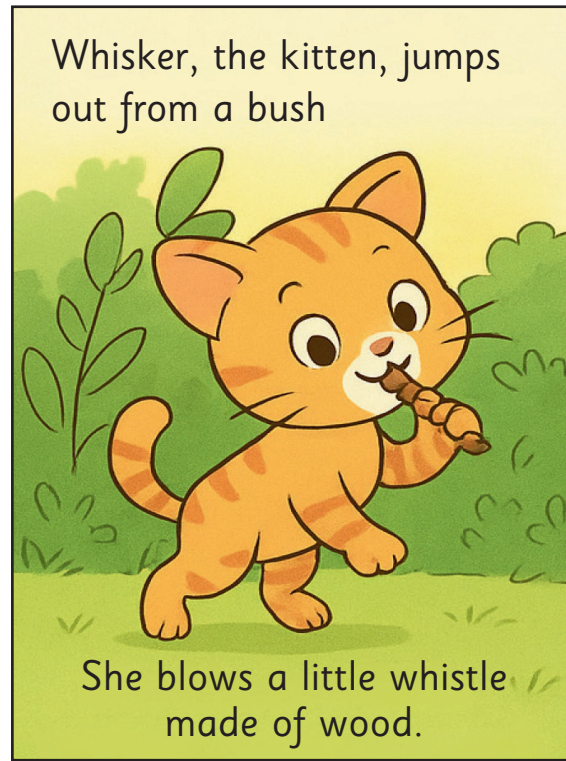
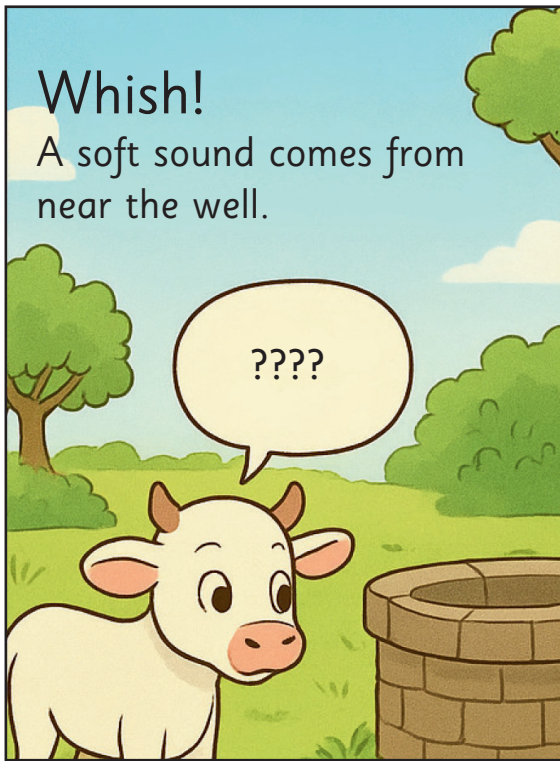

Let's learn some new words and fill the empty box with a new word.

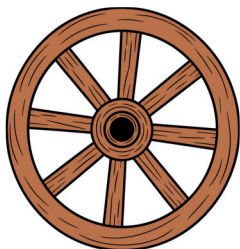

wheel

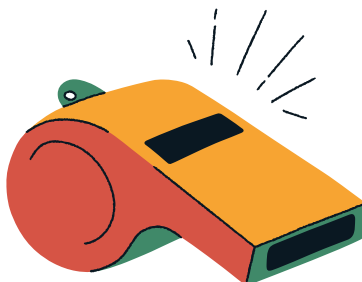

whistle



whisper



whale



wheat



white

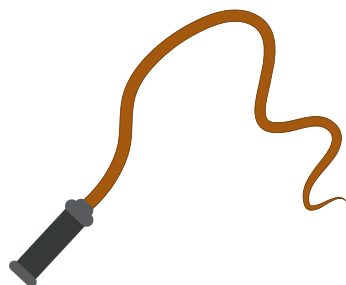

whip

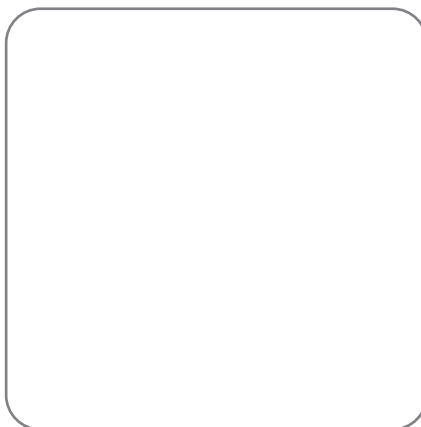

Complete the 'wh' words and colour the pictures.

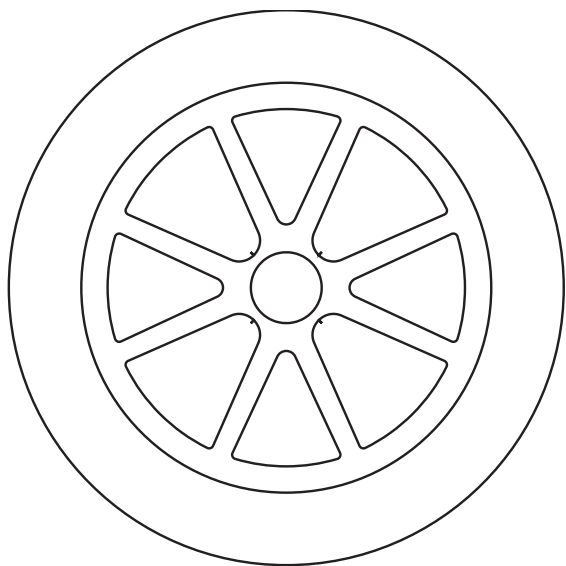

wh

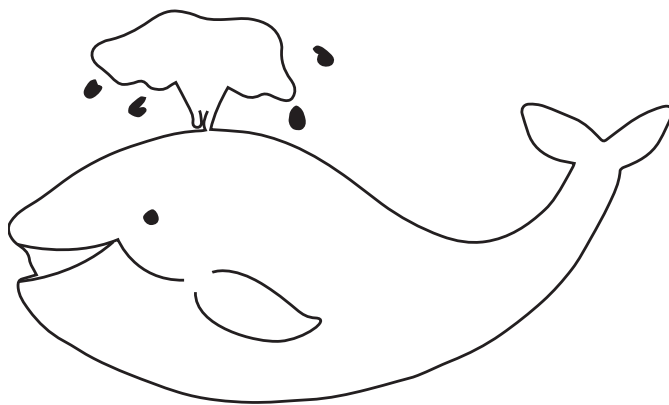

wh



wh

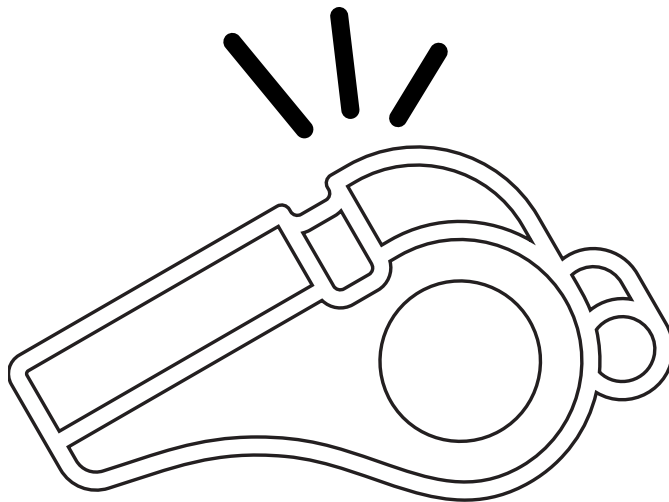

wh

Complete the sentence with 'wh' words

when



_____ time is it?

where



_____ are you crying?

who



_____ is your birthday?

what



_____ is your pen?

why



_____ is your best friend?

It's story time!

Rekha and her chick



Rekha loved her little chick



The chick would often peck at the ground in her backyard.



Rekha found a rock near the well.



She liked to stack the rock on other stone



The chick would then cluck and try to peck the stack!



Rekha and her chick had fun playing games together

What game do you play?

Digraphs

ck

Let's learn some new words.



clock



sock



lock

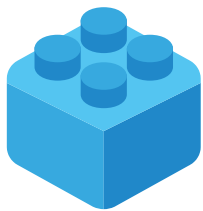

block



black



sack



rock

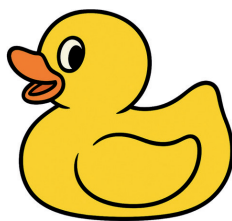

chick

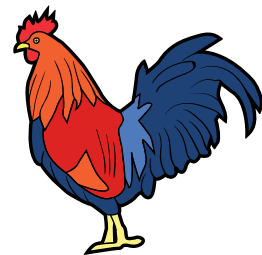

cock

Write the words.

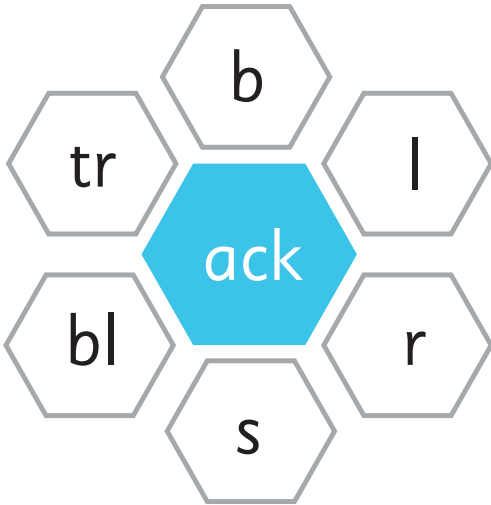

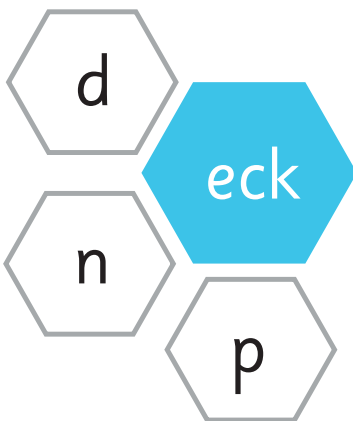
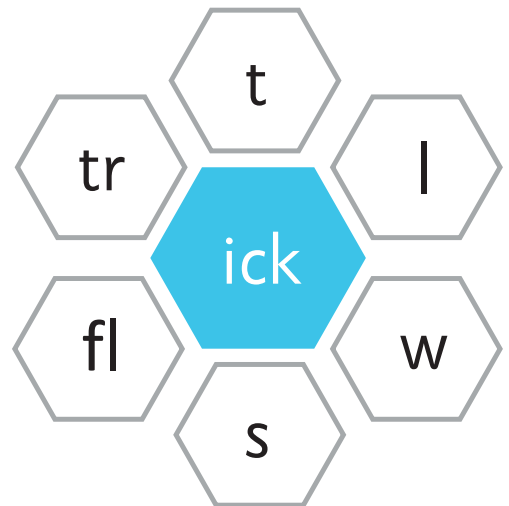

Digraphs

ck

Write the _ck words and colour the pictures.

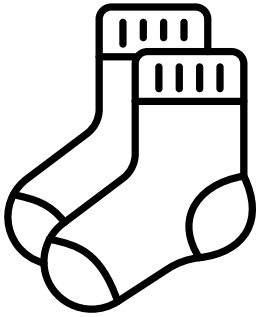

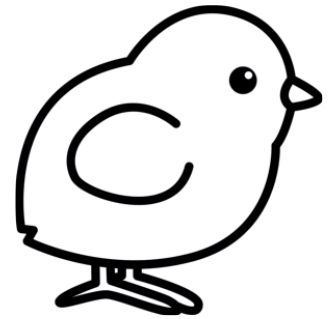

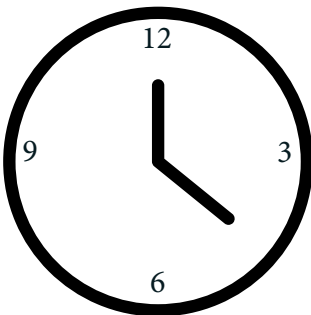
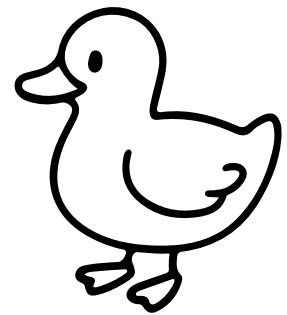

Find and write the _ck words from the picture.

buck

